



AIR QUALITY ENGINEERING

Tailored solutions from people who care



Indoor Air Quality Solutions for Machining Applications

- ▶ MistBuster® source collection and MX-Series centralized filtration

Air quality solutions from people who care

Air Quality Engineering, Inc. is a personable, responsive and independently owned U.S.-based company with a single focus of providing indoor air quality solutions delivered with a unique commitment to customer care. Since 1973, we've applied our engineering expertise to the design and manufacture of high-quality air cleaning systems.

Air Quality Engineering, Inc.'s company-based and local air quality dealers and distributors, both in the U.S. and worldwide, work hard to understand your specific concerns and goals. We then recommend and deliver the ideal clean air solution, tailored as needed, for your application.



Our people, processes and products

People

- Call our engineers, managers and air quality experts and receive prompt answers to your questions.
- Engineers specialized in:
 - Design
 - Product development
 - Product engineering
 - Applications
- We'll go the extra mile for you — before and after the installation of your new air cleaning system.

Processes

- Our consultative selling approach ensures we first understand your needs and then recommend a system that will solve your indoor air quality problems.
- The range of products and technologies available from Air Quality Engineering enables us to recommend the ideal air cleaning system for your application.
- We build and strengthen our working relationship with you based on providing honest air cleaning system performance data.

Products

We design and manufacture our own high-quality air cleaning systems, including sheet metal fabrication, using state-of-the-art equipment and lean manufacturing that:

- Provides quality control
- Increases manufacturing speed and product delivery time

Air cleaning systems that work for you

At Air Quality Engineering, Inc. our goal is to tailor an indoor air cleaning system that provides solutions for your machining application problems. Our systems deliver these benefits:

- Protect employees by reducing exposure to hazardous airborne mist, smoke and metal particles produced by industrial machining applications.¹
- Comply with indoor air quality standards and governmental regulations.
- Protect equipment.
- Reduce maintenance and operation costs.
- Meet employee and customer expectations for a clean, healthy and safe working environment.
- Improve employee retention and recruitment.

Our three-step process

We use a three-step process to learn about your unique needs and help you select, size and install the right machine tool mount or centralized air cleaning system for your shop or facility.

1. What are the contaminants?

- Mist
- Metal or other particles
- Smoke

2. How do we capture the contaminants?

- Electrostatic filtration (MistBuster source collection)
- Media filtration (MistBuster source collection and MX-Series centralized filtration)
- What are the benefits, trade-offs and your personal preferences for each type of technology?

3. What air cleaning system can we use?

- Source collection (MistBuster source collection)
- Centralized filtration (MX-Series centralized filtration)
- Tailored solution using both source collection and centralized filtration



1. Metalworking Fluids. National Institute for Occupational Safety and Health. [Online] [Cited: June 14, 2018.] [cdc.gov/niosh/topics/metalworking/](https://www.cdc.gov/niosh/topics/metalworking/)

How electrostatic filtration works

Electronic air cleaner systems use one or more permanent electronic collector cells or filters featuring electrostatic precipitation technology to collect and remove airborne mist, smoke and metal particles generated by machining applications.

An electronic collector cell is composed of an ionizing or charging section and a collection section. Incoming contaminant particles pass through an intense ionization field in the charging section. The ionization causes the particles to lose electrons and acquire a positive electrical charge.

In the collection section, positive-charged metal plates or fins repel the positively charged particles and alternating grounded fins attract the positively charged particles that coalesce and form droplets. Contaminated droplets remain trapped on the grounded fins until the collector cell is washed.

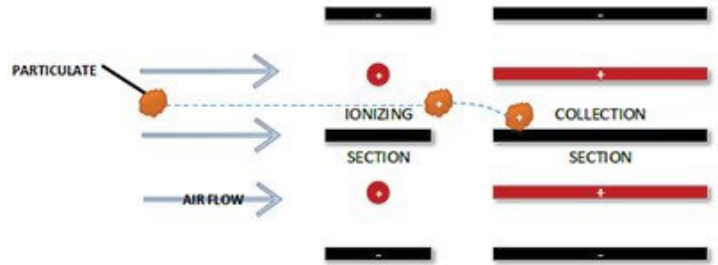

How media filtration works

Media filtration air cleaning systems for machining applications generally use a disposable fabric-type filter to efficiently capture smoke, mist and metal particles. A high efficiency particulate air (HEPA) filter is a common example of a media filter, although filters are available in a wide variety of media efficiencies, styles and materials. Air filtration mechanisms include straining, inertial impaction, interception and diffusion.

Straining

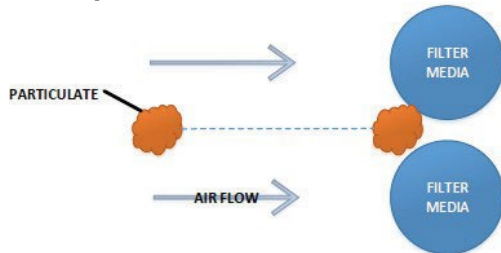

Inertial impaction

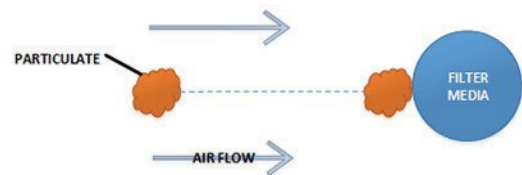

Interception

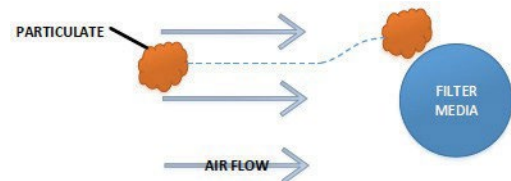

Diffusion

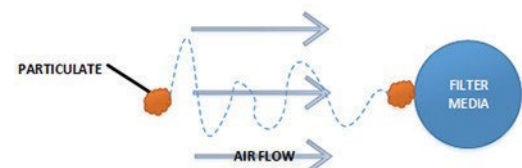

Highly efficient capture of harmful airborne contaminants

Air Quality Engineering, Inc. designs and manufactures the MistBuster family of industrial air cleaning systems for the source capture of mist and smoke generated by today's machine tools.

The MistBuster product line is highly efficient at collecting and removing dangerous airborne machining application contaminants using electrostatic precipitation and/or media filtration technologies. Options include: disposable high efficiency particulate air (HEPA) filters; extended service filter (ESF) media filters; and carbon modules for enhanced filtration and odor control.

Product line features

- Electrostatic precipitation air cleaning systems provide 97.8%–99.6% collection efficiency on all submicron particles. An optional HEPA media filter supplies up to 99.97% collection efficiency.
- Media-based air cleaning systems provide 95% minimum efficiency reporting value (MERV) 14 and 15 filter ratings.
- Electrostatic precipitation systems offer various combinations of the long-life Advantage™ and high-efficiency electronic collector cells.
- Electrostatic precipitation air cleaning systems allow you to easily switch between water-soluble or oil-based machine tool coolants.
- Our air cleaning systems have variable and controllable airflows ranging from 500 to 1,650 CFM and require minimal maintenance in wet environments.

Machining applications

- Metal machining
- Grinding/polishing
- EDM mist collectors





	ELECTROSTATIC				MEDIA	
MODEL	MB500	MB850 COMPACT	MB850	MB2000	MB500 MEDIA	MB INFINITY
Airflow	Variable to 500 CFM	Variable to 850 CFM	Variable to 850 CFM	Variable to 1,650 CFM	Variable to 500 CFM	Variable to 1,000 CFM
Primary Filter	Electrostatic	Electrostatic	Electrostatic	Electrostatic	Disposable media	Disposable media
Cabinet	16 gauge steel cabinet with powder coated chemical resistant baked enamel, available in ivory or gray textured finish	18 gauge steel cabinet with powder coated chemical resistant baked enamel, available in ivory or gray textured finish	16 gauge steel cabinet with powder coated chemical resistant baked enamel, available in ivory or gray textured finish	16 gauge steel cabinet with powder coated chemical resistant baked enamel, available in ivory or gray textured finish	16 gauge steel cabinet with powder coated chemical resistant baked enamel, available in ivory or gray textured finish	16 gauge steel cabinet with powder coated chemical resistant baked enamel, available in ivory or gray textured finish
Power Input	115 VAC, 60 Hz, 1 ph, 2.5 A 240 VAC, 60 Hz, 1 ph, 1.25 A 460 VAC, 60 Hz, 1 ph, 0.63 A (connects to 2 legs of 460 VAC 3 ph)	115 VAC, 60 Hz, 1 ph, 3.9 A 240 VAC, 60 Hz, 1 ph, 1.95 A 460 VAC, 60 Hz, 1 ph, 0.98 A (connects to two legs of 460 VAC 3 ph)	115 VAC, 60 Hz, 1 ph, 4.3 A 240 VAC, 60 Hz, 1 ph, 2.15 A 460 VAC, 60 Hz, 1 ph, 1.08 A (connects to 2 legs of 460 VAC 3 ph)	115 VAC, 60 Hz, 1 ph, 8.2 A 240 VAC, 60 Hz, 1 ph, 4.1 A	115 VAC 60 Hz, 1 ph, 3.5 A 240 VAC, 60 Hz, 1 ph, 1.75 A	115 VAC, 60 Hz, 1 ph, 9.5 A 240 VAC, 60 Hz, 1 ph, 4.75 A
Efficiency	Ultimate efficiency up to 97.8% on all submicron particles as measured by independent lab test in accordance with ASHRAE standard 52.2 at 500 CFM	Ultimate efficiency up to 98.6% on all submicron particles as measured by independent lab test in accordance with ASHRAE standard 52.2 at 600 CFM	Ultimate efficiency up to 99.4% on all submicron particles as measured by independent lab test in accordance with ASHRAE standard 52.2 at 750 CFM	Ultimate efficiency up to 99.6% on all submicron particles as measured by independent lab test in accordance with ASHRAE standard 52.2 at 1,000 CFM	95% MERV 15 Filter	95% MERV 14 Filter
Filtration Stages	1st Stage: 4" aluminum mesh impinger 2nd Stage: AQE Advantage™ electronic cell (long life) 3rd Stage: Optional HEPA filter 99.97% efficiency, ESF filter, or carbon module	1st Stage: 4" aluminum mesh impinger 2nd Stage: AQE Advantage™ electronic cell (long life) 3rd Stage: MistBuster electronic cell (high-efficiency) 4th Stage: Optional HEPA filter 99.97% efficiency, ESF filter, or carbon module	1st Stage: 4" aluminum mesh impinger 2nd Stage: AQE Advantage™ electronic cell (long life) 3rd Stage: MistBuster electronic cell (high efficiency) 4th Stage: Optional MistBuster electronic cell (high efficiency) 5th Stage: Optional HEPA filter 99.97% efficiency, ESF filter, or carbon module	1st Stage: 4" aluminum mesh impinger 2nd Stage: Two AQE Advantage™ electronic cells (long life) 3rd Stage: Two MistBuster electronic cells (high efficiency) 4th Stage: Two optional MistBuster electronic cells (high efficiency) 5th Stage: Optional HEPA filter 99.97% efficiency, or ESF filter	1st Stage: 4" aluminum mesh impinger 2nd Stage: 95% efficient MERV 15 pleated filter 3rd Stage: Optional HEPA filter 99.97% efficiency, ESF filter, or carbon module	1st Stage: 4" aluminum mesh impinger 2nd Stage: 58 sq. ft. of lofted micro-fine fiberglass media 3rd Stage: Optional HEPA filter 99.97% efficiency, ESF filter, or carbon module

Air Quality Engineering, Inc. stands behind the quality of its MistBuster product line with a limited 36-month warranty.

Specifications subject to change without notice

Air Quality Engineering, Inc. Advantage electronic collector cell

Optional high-efficiency electronic collector cell

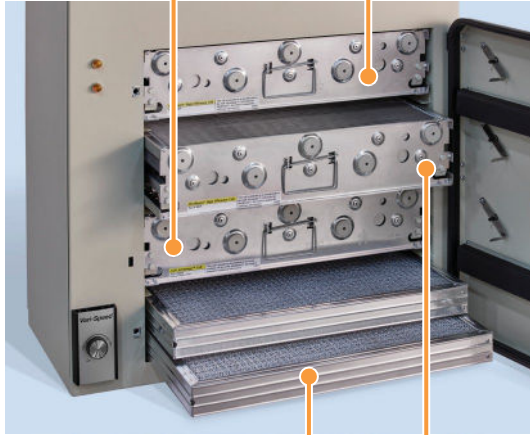

4" aluminum mesh impinger

High-efficiency electronic collector cell

Extended electronic collector cell life

The Air Quality Engineering, Inc. Advantage™ electronic collector cell greatly reduces the tendencies of high-efficiency electronic collector cells to short circuit. The patented cell design features grounded collection fins that extend further than positively charged repellent fins. The difference in fin lengths prevents positively charged droplets from bridging the conductive space between grounded and positively charged fins. This subtle change reduces the need to wash cells due to short circuiting and extends the life of electronic collector cells.

Air Quality Engineering, Inc. patented its unique collector fin design in 2002, patent #6428611. Visit air-quality-eng.com/mist-collector-video to watch a video on the electronic cell technology.

Unique geometry of motorized impeller reduces energy losses

The unique geometry of the motorized impeller improves aerodynamic efficiency, lowers energy losses and reduces noise. Because of its improved efficiency and performance, the impeller complies with the European Union's stringent Energy related Products (ErP) Directive to reduce CO₂ emissions by developing more efficient products. The impeller is CE compliant and carries both the ErP and CE marks.



For more information on the impeller, visit air-quality-eng.com/air-cleaners/mistbuster-motorized-impeller-change/.

Simply switch between water-soluble and oil-based coolants



The easy-to-use and patented water/oil selector switch from Air Quality Engineering, Inc. adjusts the electrical properties of a MistBuster system to match the type of coolant being used in a machine tool. The switch technology also helps to minimize the nuisance arcing that may occur when using

water-based coolants. Air Quality Engineering, Inc. patented its variable voltage coolant selector in 2010, patent #7717984. To learn more about the technology of our water/oil selector switch, visit air-quality-eng.com/air-cleaners/mistbuster-oil-selector-switch/.

Easy access to side-panel electrical compartment

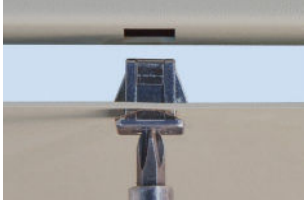

The Air Quality Engineering, Inc. MistBuster product line features quarter-turn fasteners that cannot be overly tightened. The quick-release fasteners facilitate fast and easy removal of the side-panel

door and quick access to the electrical compartment, and reduce service and repair time.

Door and gasket profile increases door-to-seal contact



The MistBuster product line designed and manufactured by Air Quality Engineering, Inc. features a door and interior gasket profile that increases the door-to-seal contact. The industrial seal prevents coolant from leaking or pooling

inside the door. Door-latch spacers prevent over-compression of the gasket and extend gasket life.

Variable-speed controller saves you energy and money

The variable-speed controller used with the MistBuster product line helps you control the airflow rate needed to maintain the right amount of negative pressure to keep contaminants contained. If the rate is too low, contaminants can migrate outside of your machine tool into the shop. If the rate is too high, contaminants that would have otherwise collected or drained back into the machine tool are drawn into the air cleaner. In addition to precisely controlling the airflow rate, the variable-speed controller saves energy and reduces noise.

Increase your mounting and ducting options

Machine shops and facilities vary in size and the space available for installing air filtration systems. To make the most efficient use of the area available in your facility or plant, Air Quality Engineering, Inc. offers a variety of mounting and ducting accessories that complement the MistBuster product line. Our lineup of MistBuster mounting options includes:



- **Direct** — unit is mounted directly on top of a machine tool, no additional ducting or accessories required
- **Pedestal stand** — unit is mounted on a floor stand and ducted to a machine tool
- **Machine mount stand** — unit is mounted on a machine tool with the stand, which allows for ducting to other sections of the machine tool enclosure
- **Ceiling or wall**

Safely and effectively wash electronic collector cells

The MistBuster® Total Cell Cleaner is a specially designed and highly effective detergent for cleaning electrostatic precipitator collector cells. The Air Quality Engineering, Inc. cleaner works on all types of machine tool coolant fluids, including petroleum-based cutting oils, water-soluble coolants and synthetics. For best results on tough-to-clean fluids, mix the liquid concentrate with warm water and wash the electronic cell in an appropriately sized container available from Air Quality Engineering, Inc.



- Safely cleans aluminum electronic collector cells
- Non-toxic and biodegradable
- Environmentally safe — no glycol ethers, hazardous air pollutants (HAPs) or volatile organic compounds (VOCs)
- Available in a gallon, 4-gallon cases and 5-gallon pails

For more information on how to wash electrostatic precipitator cells, visit air-quality-eng.com/general/wash-electrostatic-precipitator-cells/.





An electrostatic precipitation air cleaning system for the source collection and removal of mist, smoke and metal particles produced by machine tool operations. In the MistBuster family of products, the system supplies a lower spindle speed and coolant pressure (0–600 PSI).

The MistBuster 500 three-stage air filtration system features Air Quality Engineering, Inc.'s patented Advantage™ electronic collector cell and a collection efficiency of up to 97.8% on all submicron particles. Airflow is variable and controllable up to 500 CFM. Easily switch between water-soluble or oil-based machine tool coolants using Air Quality Engineering, Inc.'s patented variable voltage coolant selector.



Machining applications

- Metal machining
- Grinding/polishing
- EDM mist collectors

CE Compliant

Specifications

Airflow	Variable to 500 CFM	
Cabinet	16 gauge steel cabinet with powder coated chemical resistant baked enamel, available in ivory or gray textured finish	
Power Input	115 VAC, 60 Hz, 1 ph, 2.5 A 240 VAC, 60 Hz, 1 ph, 1.25 A 460 VAC, 60 Hz, 1 ph, 0.63 A (connects to 2 legs of 460 VAC, 3 ph)	
Efficiency	Ultimate efficiency up to 97.8% on all submicron particles as measured by independent lab test in accordance with ASHRAE standard 52.2 at 500 CFM	
Filtration Stages	1st Stage: 4" aluminum mesh impinger 2nd Stage: AQE Advantage™ electronic cell (long life)	3rd Stage: Optional HEPA filter 99.97% efficiency, ESF filter, or carbon module
Features and Benefits	<ul style="list-style-type: none"> • Energy-efficient, self-regulating, dual-voltage, solid-state power supply • Patented water/oil coolant selector for a wider range of application compatibility • Patented electronic cell design that helps decrease service intervals • ErP-compliant, backward-curved, vibration-free, direct drive motorized impeller rated at 500 CFM @ 1.3" w.g. provides energy-efficient operation and increased performance to save on operating costs while performing well with increased airflow resistance from post filter or long duct lengths 	<ul style="list-style-type: none"> • Ten-foot power cord with molded plug • Quick-release, quarter-turn fasteners for fast, easy side-panel electrical compartment access reduces service and repair time • Door and gasket profile increases door-to-seal contact to prevent leakage and pooling of coolant inside of door • Door-latch spacers prevent over-compression of the gasket and increase gasket life <p>This unit is to be used exclusively for source control in industrial applications.</p>

Specifications continued

Dimensions	Cabinet: 27.10"L x 14.00"W x 17.16"H	
Inlet Opening	16.62" x 9.08"	
Weight	65 lbs. installed; 76 lbs. shipping (capable of being shipped via UPS)	
Accessories	Machine mount stand Pedestal stand Ceiling mount kit Wall mount kit	Plenum Diffuser HEPA post filter ESF post filter Carbon module

Specifications subject to change without notice

Dimensions*

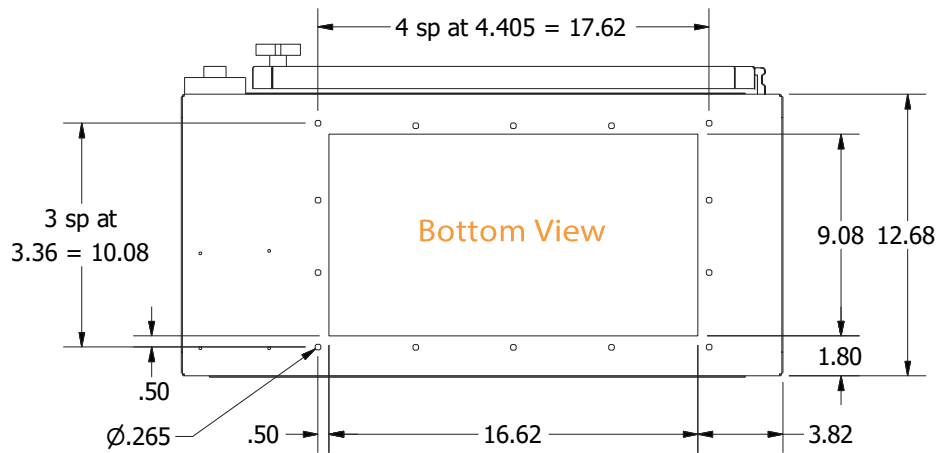
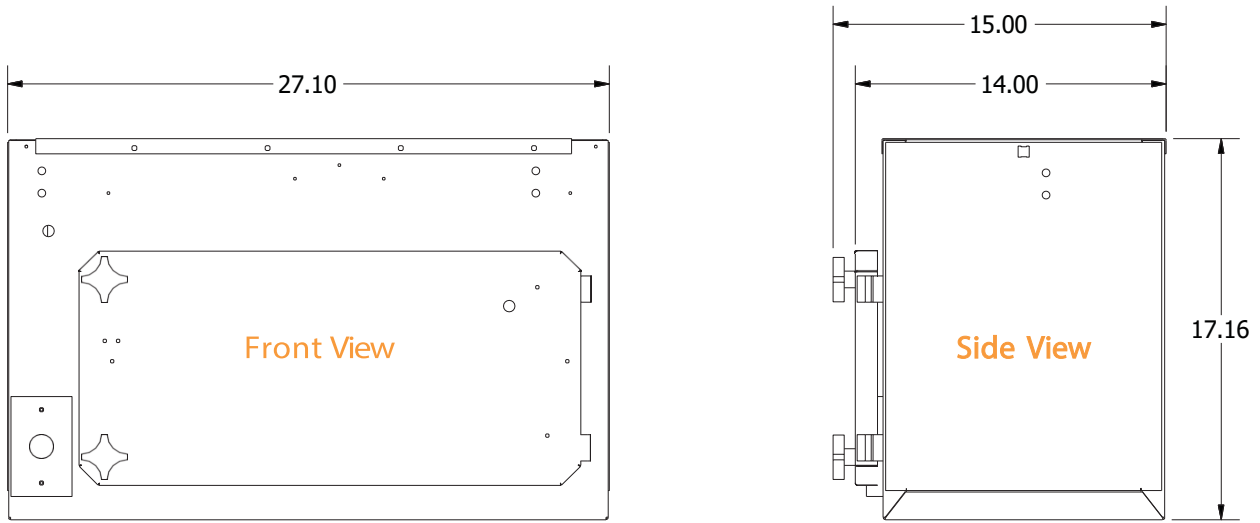

*All measurements in inches



A compact version of the MistBuster 850 electrostatic precipitation air cleaning system for the source capture and removal of smoke, mist and metal particles generated by today's machining applications. In the MistBuster product family, the system provides a higher spindle speed and coolant pressure (600–1,500 PSI).

The MistBuster 850 Compact four-stage air filtration system features Air Quality Engineering, Inc.'s patented Advantage™ electronic collector cell and an additional high-efficiency electronic collector cell. The electronic collector cells provide a collection efficiency up to 98.6% on all submicron particles. Using Air Quality Engineering, Inc.'s patented variable voltage coolant selector, simply switch between water-soluble or oil-based machine tool coolants. Airflow is variable and controllable up to 850 CFM.

Machining applications

- Metal machining
- EDM mist collectors
- Grinding/polishing

CE Compliant

Specifications

Airflow	Variable to 850 CFM	
Cabinet	18 gauge steel cabinet with powder coated chemical resistant baked enamel, available in ivory or gray textured finish	
Power Input	115 VAC, 60 Hz, 1 ph, 3.9 A 240 VAC, 60 Hz, 1 ph, 1.95 A 460 VAC, 60 Hz, 1 ph, 0.98 A (connects to two legs of 460 VAC, 3 ph)	
Efficiency	Ultimate efficiency up to 98.6% on all submicron particles as measured by independent lab test in accordance with ASHRAE standard 52.2 at 600 CFM	
Filtration Stages	1st Stage: 4" aluminum mesh impinger 2nd Stage: AQE Advantage™ electronic cell (long life) 3rd Stage: MistBuster electronic cell (high-efficiency)	4th Stage: Optional HEPA filter 99.97% efficiency, ESF filter, or carbon module
Features and Benefits	<ul style="list-style-type: none"> • Energy efficient, self-regulating, dual-voltage, solid-state power supply • Patented water/oil coolant selector for a wider range of application compatibility • Patented electronic cell design that helps decrease service intervals • ErP-compliant, backward-curved, vibration-free, direct drive motorized impeller rated at 850 CFM @ 1.1" w.g. provides energy-efficient operation and increased performance to save on operating costs while performing well with increased airflow resistance from post filter or long duct lengths 	<ul style="list-style-type: none"> • Ten-foot power cord with molded plug • Quick-release, quarter-turn fasteners for fast, easy side-panel electrical compartment access reduces service and repair time • Door and gasket profile increases door-to-seal contact to prevent leakage and pooling of coolant inside of door • Door-latch spacers prevent over-compression of the gasket and increase gasket life <p>This unit is to be used exclusively for source control in industrial applications in California.</p>

Air Quality Engineering, Inc. stands behind the quality of its MistBuster product line with a limited 36-month warranty.

Specifications subject to change without notice

Specifications continued

Dimensions	Cabinet: 27.10"L x 14.00"W x 22.42"H	
Inlet Opening	16.62" x 9.08"	
Weight	93 lbs. installed; 105 lbs. shipping	
Accessories	Machine mount stand Pedestal stand Ceiling mount kit Wall mount kit	Plenum Diffuser HEPA post filter ESF post filter Carbon module

Specifications subject to change without notice

Dimensions*

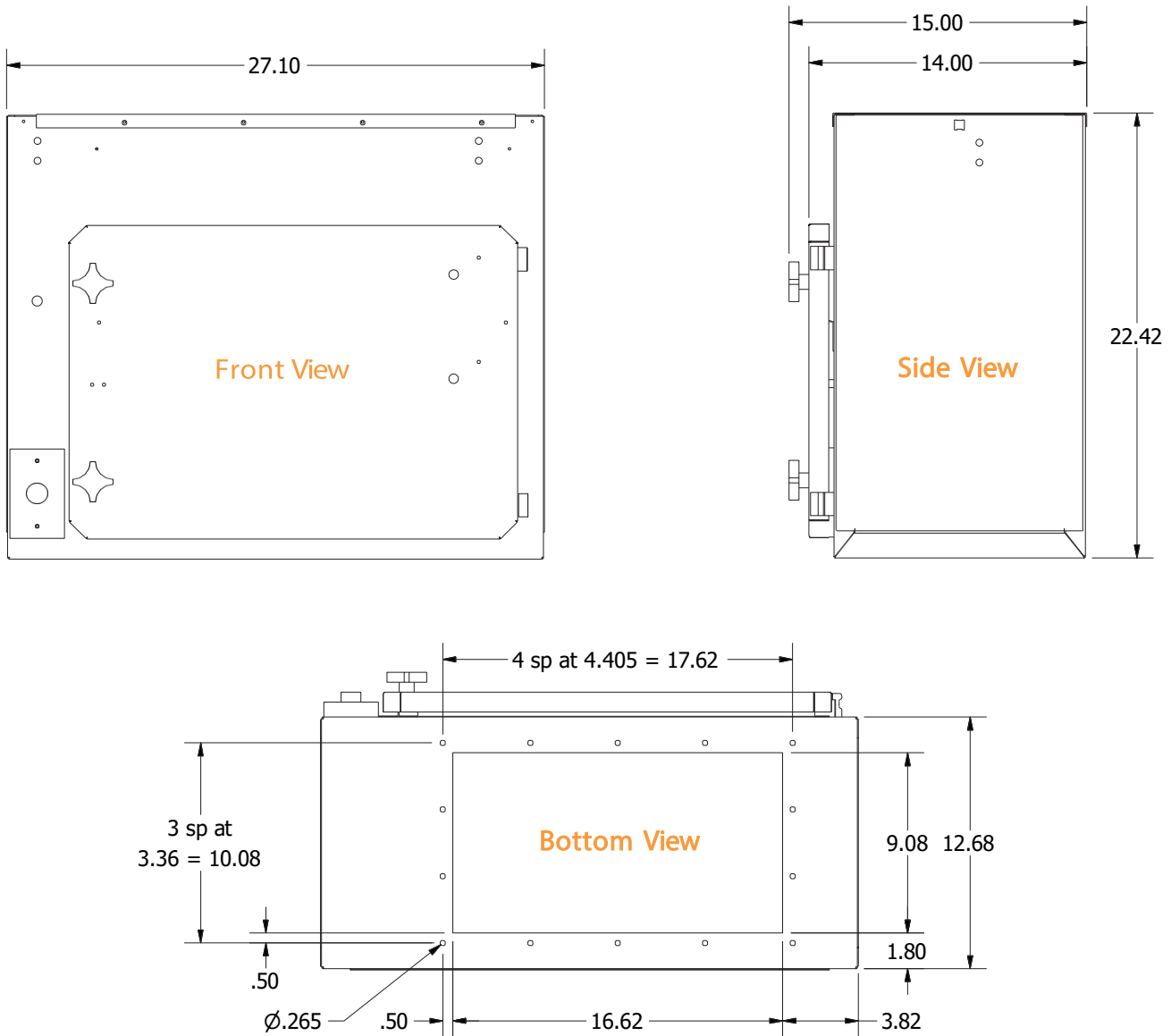

*All measurements in inches



An electrostatic precipitation air cleaning system for the source collection and removal of smoke, mist and metal particle contaminants produced from machine tool coolant fluids. In the MistBuster family of products, the system supplies a higher spindle speed and coolant pressure (600–1,500 PSI).

The MistBuster 850 five-stage air filtration system features Air Quality Engineering, Inc.'s patented Advantage™ electronic collector cell and one or two high-efficiency electronic collector cells. The electronic collector cells provide a collection efficiency up to 99.4% on all submicron particles. An optional fifth-stage HEPA filter offers filtration efficiency up to 99.97%. Airflow is variable and controllable up to 850 CFM. Easily switch between water-soluble or oil-based machine tool coolants using Air Quality Engineering, Inc.'s patented variable voltage coolant selector.

Machining applications

- Metal machining
- EDM mist collectors
- Grinding/polishing

CE Compliant

Specifications

Airflow	Variable to 850 CFM	
Cabinet	16 gauge steel cabinet with powder coated chemical resistant baked enamel, available in ivory or gray textured finish	
Power Input	115 VAC, 60 Hz, 1 ph, 4.3 A 240 VAC, 60 Hz, 1 ph, 2.15 A 460 VAC, 60 Hz, 1 ph, 1.08 A (connects to 2 legs of 460 VAC, 3 ph)	
Efficiency	Ultimate efficiency up to 99.4% on all submicron particles as measured by independent lab test in accordance with ASHRAE standard 52.2 at 750 CFM	
Filtration Stages	1st Stage: 4" aluminum mesh impinger 2nd Stage: AQE Advantage™ electronic cell (long life) 3rd Stage: MistBuster electronic cell (high efficiency)	4th Stage: Optional MistBuster electronic cell (high efficiency) 5th Stage: Optional HEPA filter 99.97% efficiency, ESF filter, or carbon module
Features and Benefits	<ul style="list-style-type: none"> • Two energy-efficient, self-regulating, dual-voltage, solid-state power supplies • Patented water/oil coolant selector for a wider range of application compatibility • Patented electronic cell design that helps decrease service intervals • ErP-compliant, backward-curved, vibration-free, direct drive motorized impeller rated at 850 CFM @ 1.1" w.g. provides energy-efficient operation and increased performance to save on operating costs while performing well with increased airflow resistance from post filter or long duct lengths 	<ul style="list-style-type: none"> • Ten-foot power cord with molded plug • Quick-release, quarter-turn fasteners for fast, easy side-panel electrical compartment access reduces service and repair time • Door and gasket profile increases door-to-seal contact to prevent leakage and pooling of coolant inside of door • Door-latch spacers prevent over-compression of the gasket and increase gasket life.

This unit is to be used exclusively for source control in industrial applications in California.

Specifications continued

Dimensions	Cabinet: 27.10"L x 14.00"W x 27.47"H	
Inlet Opening	16.62" x 9.08"	
Weight	99 lbs. installed; 111 lbs. shipping (2 cells) 113 lbs. installed; 125 lbs. shipping (3 cells)	
Accessories	Machine mount stand Pedestal stand Ceiling mount kit Wall mount kit	Plenum Diffuser HEPA post filter ESF post filter Carbon module

Specifications subject to change without notice

Dimensions*

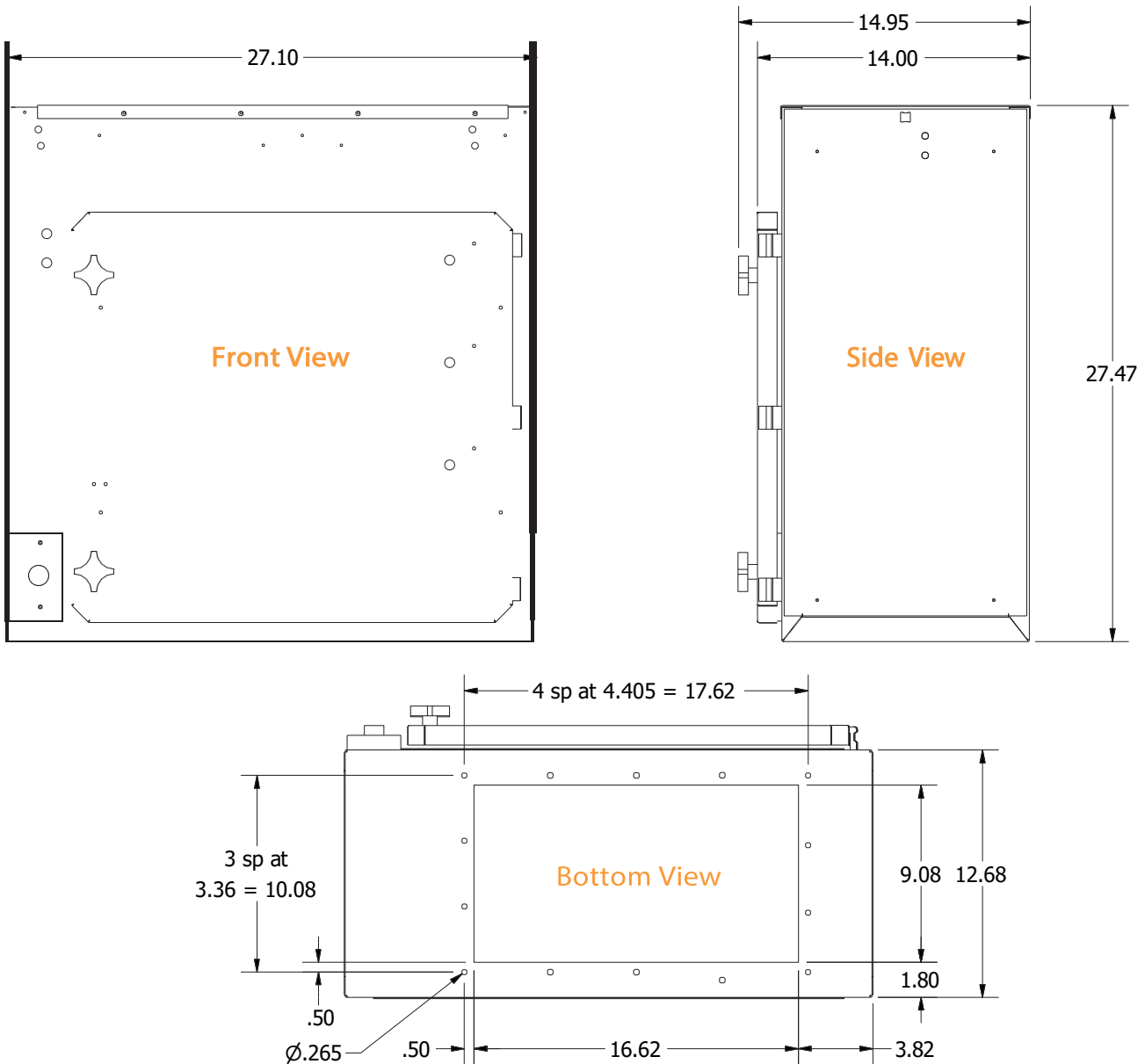

*All measurements in inches



An electrostatic precipitation air cleaning system for the source capture and removal of mist, smoke and metal particles produced by machining applications. The system provides the highest spindle speed and coolant pressure (1,500–2,000 PSI) in the MistBuster product family.

The MistBuster 2000 five-stage air cleaning system features two of Air Quality Engineering, Inc.'s patented Advantage™ electronic collector cells in stage two, two high-efficiency electronic collector cells in stage three and an optional two high-efficiency electronic collector cells in stage four. The collector cells provide a filtration efficiency up to 99.6% on all submicron particles. Using Air Quality Engineering, Inc.'s patented variable voltage coolant selector, simply switch between water-soluble or oil-based machine tool coolant fluids. Airflow is variable and controllable up to 1,650 CFM.

Machining applications

- Metal machining
- EDM mist collectors
- Grinding/polishing

CE Compliant

Specifications

Airflow	Variable to 1,650 CFM	
Cabinet	16 gauge steel cabinet with powder coated chemical resistant baked enamel, available in ivory or gray textured finish	
Power Input	115 VAC, 60 Hz, 1 ph, 8.2 A 240 VAC, 60 Hz, 1 ph, 4.1 A	
Efficiency	Ultimate efficiency up to 99.6% on all submicron particles as measured by independent lab test in accordance with ASHRAE standard 52.2 at 1,000 CFM	
Filtration Stages	<p>1st Stage: 4" aluminum mesh impinger</p> <p>2nd Stage: Two AQE Advantage™ electronic cells (long life)</p> <p>3rd Stage: Two MistBuster electronic cells (high efficiency)</p>	<p>4th Stage: Two optional MistBuster electronic cells (high efficiency)</p> <p>5th Stage: Optional HEPA filter 99.97% efficiency, or ESF filter</p>
Features and Benefits	<ul style="list-style-type: none"> • Two energy-efficient, self-regulating, dual-voltage, solid-state power supplies • Patented water/oil coolant selector for a wider range of application compatibility • Patented electronic cell design that helps decrease service intervals • ErP-compliant, backward-curved, vibration-free, direct drive motorized impeller rated at 850 CFM @ 1.1" w.g. provides energy-efficient operation and increased performance to save on operating costs while performing well with increased airflow resistance from post filter or long duct lengths 	<ul style="list-style-type: none"> • Ten-foot power cord with molded plug • Quick-release, quarter-turn fasteners for fast, easy side-panel electrical compartment access reduces service and repair time • Door and gasket profile increases door-to-seal contact to prevent leakage and pooling of coolant inside of door • Door-latch spacers prevent over-compression of the gasket and increase gasket life.

This unit is to be used exclusively for source control in industrial applications in California.

Air Quality Engineering, Inc. stands behind the quality of its MistBuster product line with a limited 36-month warranty.

Specifications subject to change without notice

Specifications continued

Dimensions	Cabinet: 25.98"L x 26.56"W x 27.49"H	
Inlet Opening	16" x 20.75"	
Weight	203 lbs. installed; 230 lbs. shipping	
Accessories	Machine mount stand Pedestal stand Ceiling mount kit Wall mount kit	Plenum Diffuser HEPA post filter ESF post filter

Specifications subject to change without notice

Dimensions*

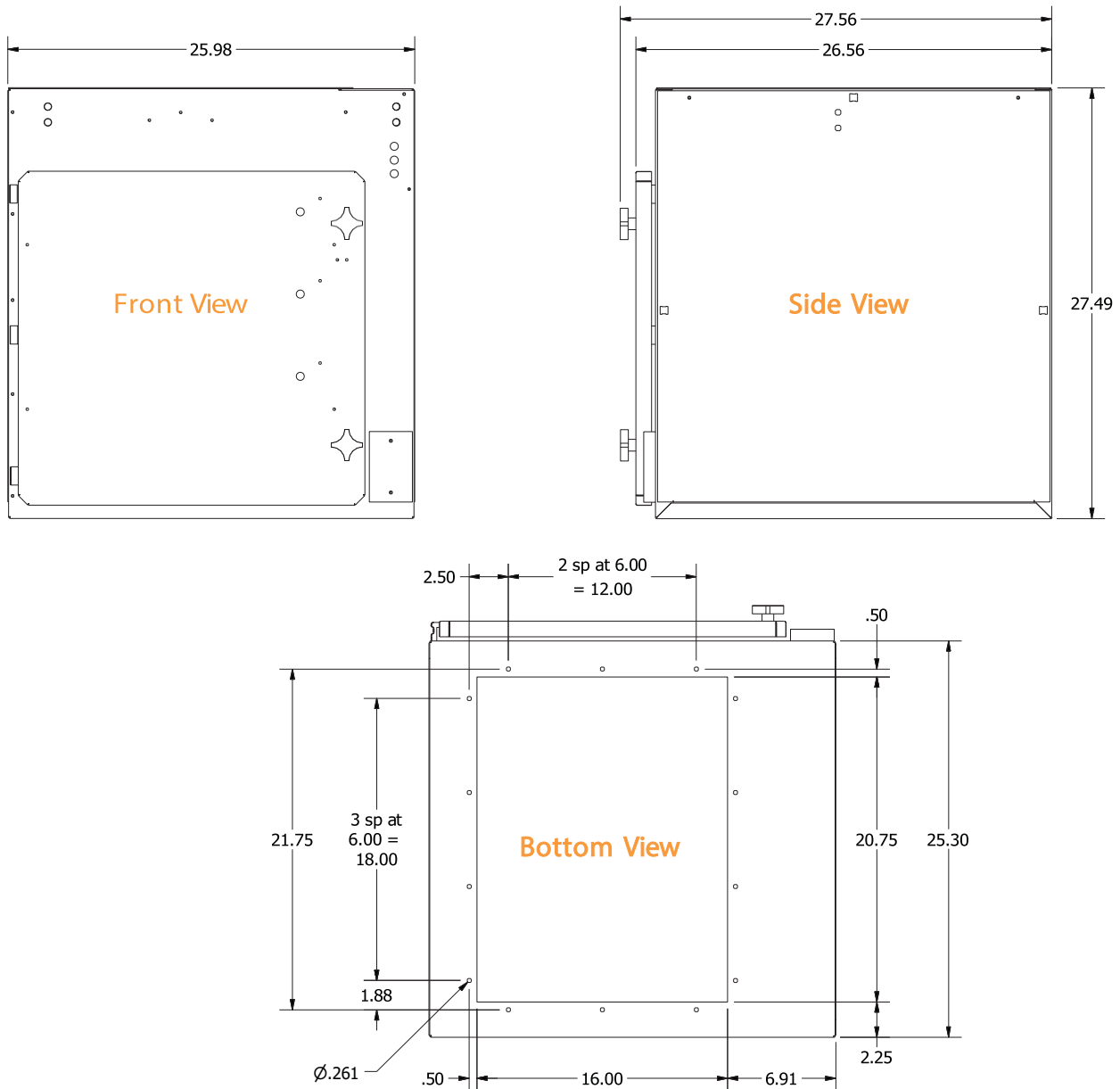

*All measurements in inches



A media-based air cleaning system for the source collection of smoke, mist and metal particles produced by machining applications. The system uses a second-stage MERV 15 pleated filter.

The MistBuster 500 Media three-stage air cleaning system provides up to 95% collection efficiency using a disposable MERV 15 pleated filter. Airflow is variable and controllable up to 500 CFM.

Machining applications

- Metal machining
- Grinding/polishing
- EDM mist collectors



Specifications

Airflow	Variable to 500 CFM	
Cabinet	16 gauge steel cabinet with powder coated chemical resistant baked enamel, available in ivory or gray textured finish	
Power Input	115 VAC 60 Hz, 1 ph, 3.5 A 240 VAC, 60 Hz, 1 ph, 1.75 A	
Efficiency	95% MERV 15 Filter	
Filtration Stages	1st Stage: 4" aluminum mesh impinger 2nd Stage: 95% efficient MERV 15 pleated filter	3rd Stage: Optional HEPA filter 99.97% efficiency, ESF filter, or carbon module
Features and Benefits	<ul style="list-style-type: none"> • ErP-compliant, backward-curved, vibration-free, direct drive motorized impeller rated at 500 CFM @ 2.5" w.g. provides energy-efficient operation and increased performance to save on operating costs while performing well with increased airflow resistance from post filter or long duct lengths • Ten-foot power cord with molded plug 	<ul style="list-style-type: none"> • Quick-release, quarter-turn fasteners for fast, easy side-panel electrical compartment access reduces service and repair time • Door and gasket profile increases door-to-seal contact to prevent leakage and pooling of coolant inside of door • Door-latch spacers prevent over-compression of the gasket and increase gasket life

This unit is to be used exclusively for source control in industrial applications in California.

Specifications continued

Dimensions	Cabinet: 27.10"L x 14.00"W x 17.16"H	
Inlet Opening	16.62" x 9.08"	
Weight	58 lbs. installed; 69 lbs. shipping (capable of being shipped via UPS)	
Accessories	Machine mount stand Pedestal stand Ceiling mount kit Wall mount kit	Plenum Diffuser HEPA post filter ESF post filter Carbon module

Specifications subject to change without notice

Dimensions*

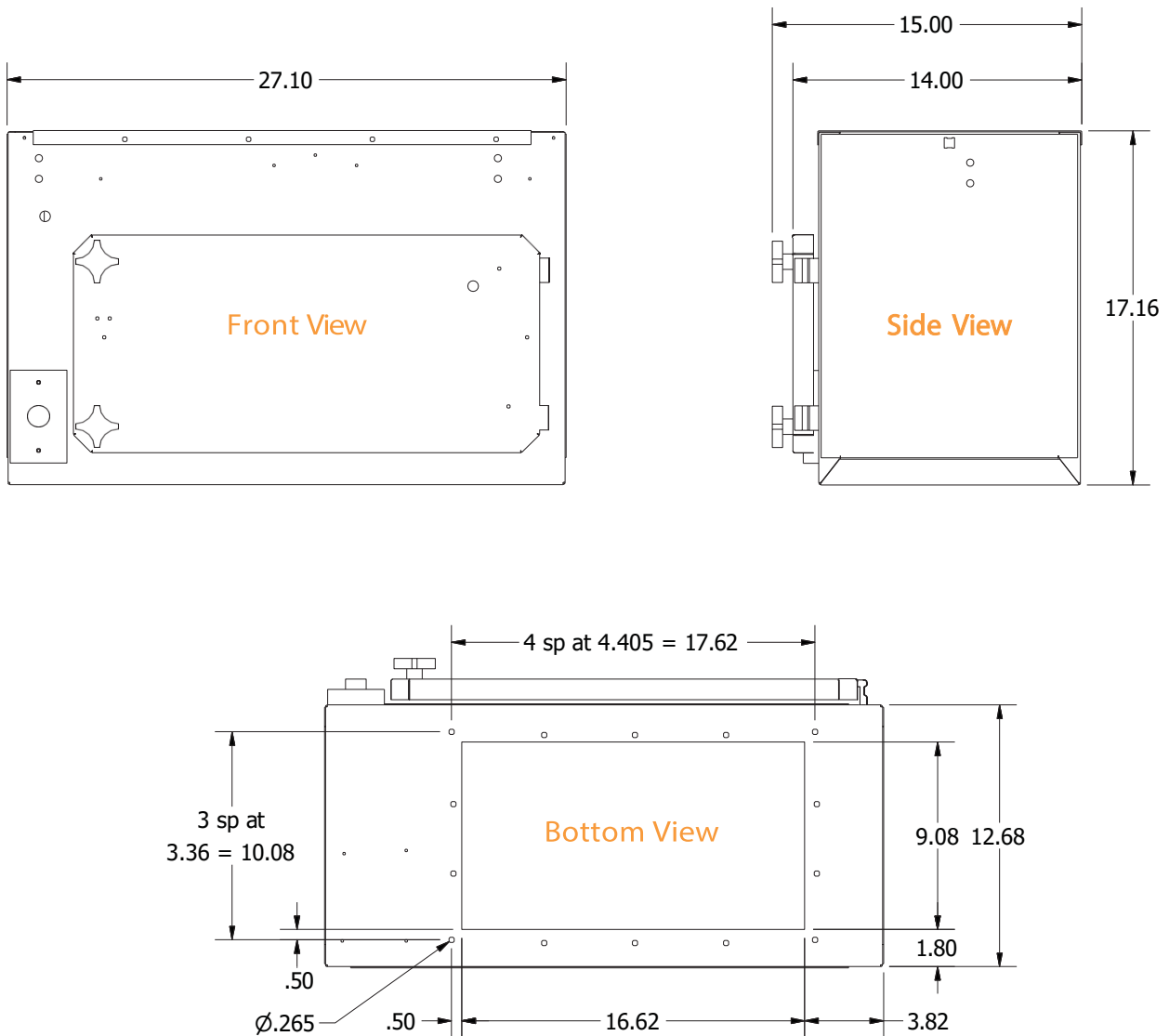

*All measurements in inches



A media-based air filtration system for the collection and removal of mist, smoke and metal particles produced by machine tool operations. The system uses 58 sq. ft. of lofted micro-fine fiberglass media in its second filtration stage.

The MistBuster Infinity three-stage air cleaning system provides up to 95% MERV 14 filter collection efficiency and is ideal for cast iron machining applications. An optional third-stage HEPA filter offers filtration efficiency up to 99.97%. Airflow is variable and controllable up to 1,000 CFM.

Machining applications

- Metal machining
- Grinding/polishing
- EDM mist collectors



Specifications

Airflow	Variable to 1,000 CFM	
Cabinet	16 gauge steel cabinet with powder coated chemical resistant baked enamel, available in ivory or gray textured finish	
Power Input	115 VAC, 60 Hz, 1 ph, 9.5 A 240 VAC, 60 Hz, 1 ph, 4.75 A	
Efficiency	95% MERV 14 Filter	
Filtration Stages	1st Stage: 4" aluminum mesh impinger 2nd Stage: 58 sq. ft. of lofted micro-fine fiberglass media	3rd Stage: Optional HEPA filter 99.97% efficiency, ESF filter, or carbon module
Features and Benefits	<ul style="list-style-type: none"> • Backward-curved, vibration-free, direct drive motorized impeller rated at 1,000 CFM @ 3.0" w.g. provides energy-efficient operation and increased performance to save on operating costs while performing well to obtain full life out of the media filters while overcoming the resistance of duct • Standard size prefilter and main filter track size allows for the use of a variety of filter media for a wide range of applications 	<ul style="list-style-type: none"> • Ten-foot power cord with molded plug • Dirty filter gauge for easy monitoring of filter status • Infinitely variable fan speed controller provides easy airflow adjustment to obtain the desired airflow for your application

This unit is to be used exclusively for source control in industrial applications in California.

Air Quality Engineering, Inc. stands behind the quality of its MistBuster product line with a limited 36-month warranty.

Specifications subject to change without notice

Specifications continued

Dimensions	Cabinet: 27.10"L x 26.25"W x 31.64"H	
Inlet Opening	22.25" x 23.10"	
Weight	185 lbs. installed; 200 lbs. shipping	
Accessories	Machine mount stand Pedestal stand Ceiling mount kit Wall mount kit	Plenum HEPA post filter ESF post filter Carbon module Long life filter

Specifications subject to change without notice

Dimensions*

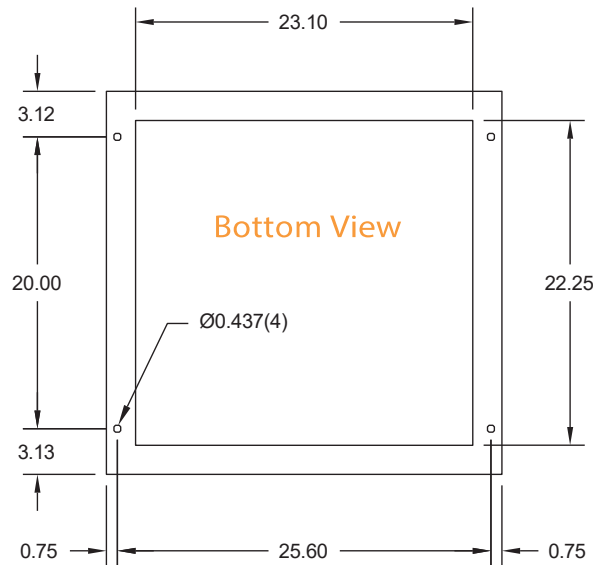
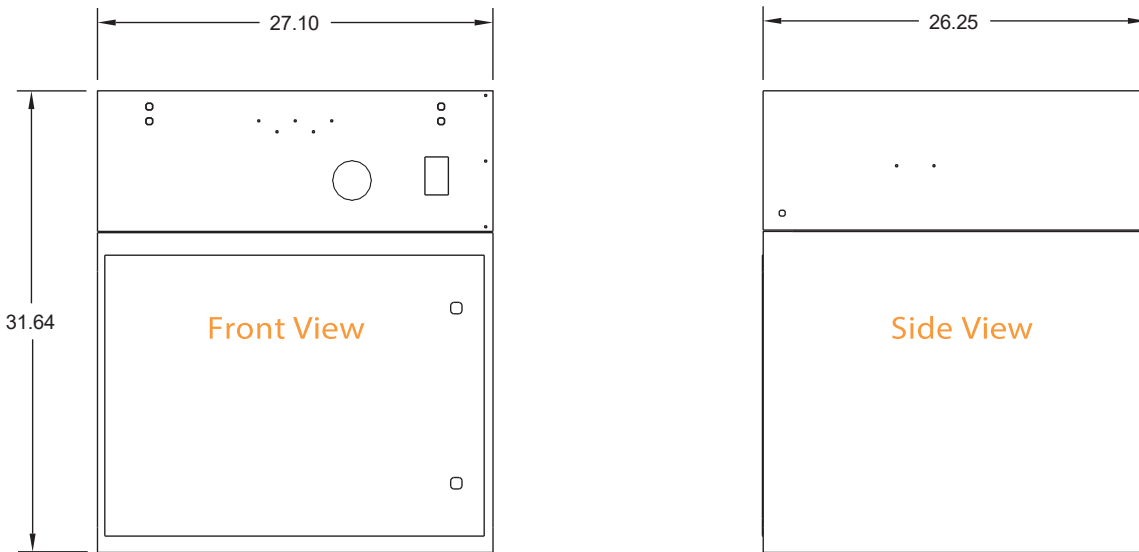

*All measurements in inches

Centralized filtration of hazardous airborne particles

Air Quality Engineering, Inc. designs and manufactures the MX-Series product line of industrial air cleaners for the centralized filtration of mist, smoke and metal particles produced by machining applications. The MX-Series product family uses disposable media filters and includes self-contained systems (M330 and M660) and the MX660 series (M2660, M3660 and M4660).



The M330 and M660 systems are designed to be floor or ceiling mounted and ducted to multiple machine tools.

These systems can be custom configured with multiple stages of filtration to meet your air cleaning needs and maximize filter life. Blower options include belt-driven, forward-curved blowers and direct-drive, backward inclined wheels.

The MX660 series includes large industrial media-based air cleaning systems. Scalable configurations of the MX660 series may include either two, three or four M660 systems based on your shop or plant's air flow requirements and the motor and blower package you select. Custom motors and blowers are available for a wide variety of machining applications.

The MX-Series product line provides airflow capacities ranging from 1,000 CFM to 8,000 CFM. The air cleaning systems are designed with multi-stage pre-filter and primary filter options and are customizable to collect and remove your specific particle contaminants. The M660, M2660, M3660 and M4660 systems can be equipped with HEPA filtration and/or odor modules for increased filter efficiency and vapor/odor control.



Machining applications

- Metal machining
- Grinding/polishing
- EDM mist collectors





MODEL	M330	M660	M2660, M3660, M4660	
Airflow	1,000 CFM	2,000 CFM	M2660: 4,000 CFM; M3660: 6,000 CFM; M4660: 8,000 CFM	
Cabinet	16 gauge steel cabinet with powder coated chemical resistant baked enamel, available in ivory textured finish	16 gauge steel cabinet with powder coated chemical resistant baked enamel with ivory textured finish	16 gauge steel cabinet with powder coated chemical resistant baked enamel with ivory textured finish	
Power Input	115 VAC, 60 Hz, 1 ph 230 VAC, 60 Hz, 1 ph	110–120 VAC, 60 Hz, 1 ph 208–240 VAC, 60 Hz, 1 ph	208–240 VAC, 60 Hz, 3 ph 440–480 VAC, 60 Hz, 3 ph	208–240 VAC, 60 Hz, 3 ph 440–480 VAC, 60 Hz, 3 ph <i>International voltages available</i>
Motor Options	1 HP, 1-1/2 HP	1 HP, 1-1/2 HP, 2 HP, 3 HP, 5 HP	3 HP, 5 HP, 7-1/2 HP, 10 HP, 15 HP <i>Custom motors selected per application</i>	
Blower Options	Belt-driven, forward-curved	Belt-driven, forward-curved Direct-drive, backward-inclined	Direct-drive, backward-inclined <i>Custom blowers selected per application</i> <i>Motor-blower packages sold separately</i>	
Filter Options: Prefilter	Two 12" x 24" x 2" mist impingers One 12" x 24" x 4" pleated prefilter MERV 8	Two 24" x 24" x 2" mist impingers One 24" x 24" x 4" pleated prefilter MERV 8 One 24" x 24" x 4" pleated prefilter MERV 11	24" x 24" x 2" mist impingers 24" x 24" x 4" pleated prefilter MERV 8 24" x 24" x 4" pleated prefilter MERV 11 <i>Quantity determined based on application</i>	
Filter Options: Primary	One 12" x 24" x 26" MERV 14 bag filter One 12" x 24" x 26" MERV 13 bag filter One 12" x 24" x 12" polypropylene ESF MERV 14 One 12" x 24" x 12" polypropylene ESF MERV 13	One 24" x 24" x 26" MERV 14 bag filter One 24" x 24" x 26" MERV 13 bag filter One 24" x 24" x 12" polypropylene ESF MERV 14 One 24" x 24" x 12" polypropylene ESF MERV 13	24" x 24" x 26" MERV 14 bag filter 24" x 24" x 26" MERV 13 bag filter 24" x 24" x 12" polypropylene ESF MERV 14 24" x 24" x 12" polypropylene ESF MERV 13 M2660: 2/unit; M3660: 3/unit; M4660: 4/unit	
Accessories	One to two 22 lbs. odor modules Wall mount arm	45 lbs. odor module(s) HEPA filter module Additional pre-filtration	Wall mount arm Silencer	45 lbs. odor module(s) HEPA filter modules Additional pre-filtration Wall mount arm Silencer

Air Quality Engineering, Inc. stands behind the quality of its MX-Series product line with a limited 12-month warranty.

Specifications subject to change without notice

Specifications

Airflow	1,000 CFM	
Cabinet	16 gauge steel cabinet with powder coated chemical resistant baked enamel with ivory textured finish	
Power Input	115 VAC, 60Hz, 1 ph 230 VAC, 60 Hz, 1 ph	
Motor Options	1 HP, 1-1/2 HP	
Blower Options	Belt-driven, forward-curved	
Filter Options: Prefilter	Two 12" x 24" x 2" mist impingers One 12" x 24" x 4" pleated prefilter MERV 8	
Filter Options: Primary	One 12" x 24" x 26" MERV 14 bag filter One 12" x 24" x 26" MERV 13 bag filter	One 12" x 24" x 12" polypropylene ESF MERV 14 One 12" x 24" x 12" polypropylene ESF MERV 13
Accessories	One to two 22 lbs. odor modules	Wall mount arm
Weight	305 lbs. installed; 340 lbs. shipping	
Features and Benefits	<ul style="list-style-type: none"> • Standard 1 HP and optional 1-1/2 HP belt-drive blower with adjustable sheave to handle a wide range of applications • Dirty filter gauge for easy monitoring of filter status • Power indicator light • 10-foot power cord with molded plug • Dual 8" collars for duct installation flexibility 	<ul style="list-style-type: none"> • Standard size prefilter and main filter track size allows for the use of a variety of filter media for a wide range of applications • Drain connection to return collected oil/coolant back to the machine tool or to collect anything that drains off the filters in the air cleaner

Specifications subject to change without notion.

This unit is to be used exclusively for source control in industrial applications in California.

Dimensions*

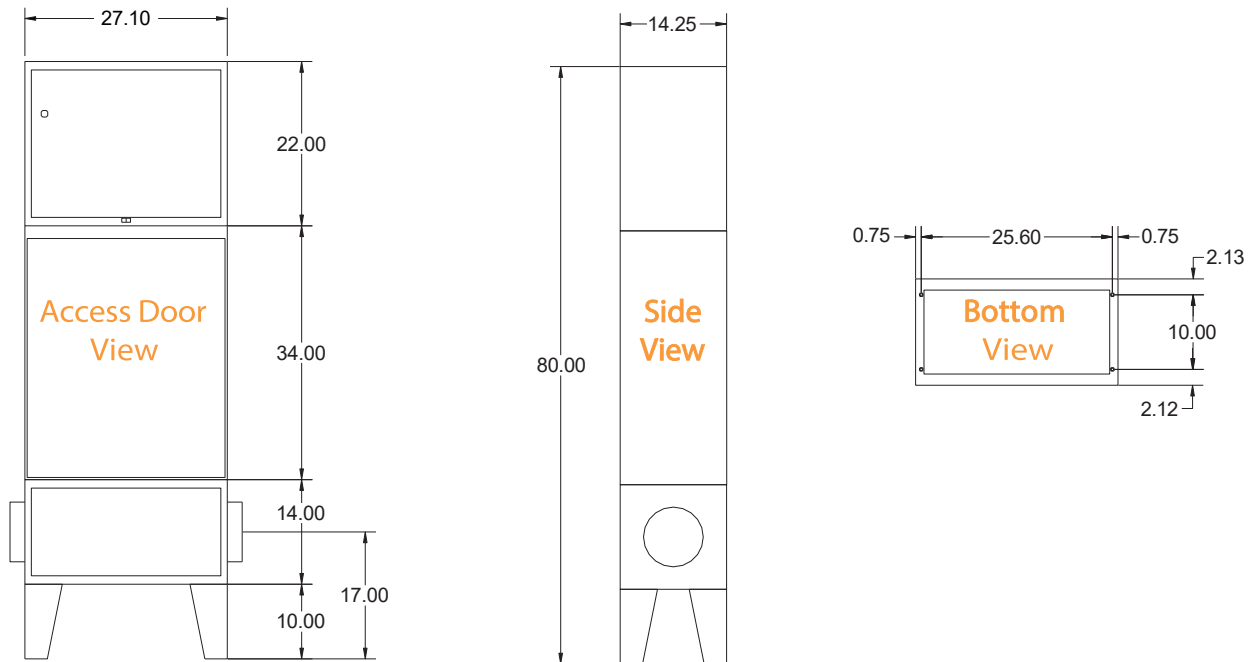

*All measurements in inches

Specifications

Airflow	2,000 CFM	
Cabinet	16 gauge steel cabinet with powder coated chemical resistant baked enamel with ivory textured finish	
Power Input	110–120 VAC, 60 Hz, 1 ph 208–240 VAC, 60 Hz, 1 ph	208–240 VAC, 60 Hz, 3 ph 440–480 VAC, 60 Hz, 3 ph
Motor Options	1 HP, 1-1/2 HP, 2 HP, 3 HP, 5 HP	
Blower Options	Belt-driven, forward-curved Direct-drive, backward-inclined	
Filter Options: Prefilter	Two 24" x 24" x 2" mist Impingers One 24" x 24" x 4" pleated prefilter MERV 8	One 24" x 24" x 4" pleated prefilter MERV 11
Filter Options: Primary	One 24" x 24" x 26" MERV 14 bag filter One 24" x 24" x 26" MERV 13 bag filter	One 24" x 24" x 12" polypropylene ESF MERV 14 One 24" x 24" x 12" polypropylene ESF MERV 13
Accessories	45 lbs. odor module(s) HEPA filter module Additional pre-filtration	Wall mount arm Silencer
Weight	360 lbs. installed; 430 lbs. shipping	
Features and Benefits	<ul style="list-style-type: none"> • Variety of motor and blower configurations to handle a wide range of applications • Direct-drive, backward-inclined optional for applications requiring higher static due to ductwork • Optional silencer for applications that demand quiet operation • Dirty filter gauge for easy monitoring of filter status • Power indicator light • 10-foot power cord with molded plug (single phase only) • Standard size prefilter and main filter track size allows for the use of a variety of filter media for a wide range of applications • Drain connection to return collected oil/coolant back to the machine tool or to collect anything that drains off the filters in the air cleaner • Dual 8" collars for duct installation flexibility 	

Dimensions*

Specifications subject to change without notice.

This unit is to be used exclusively for source control in industrial applications in California.

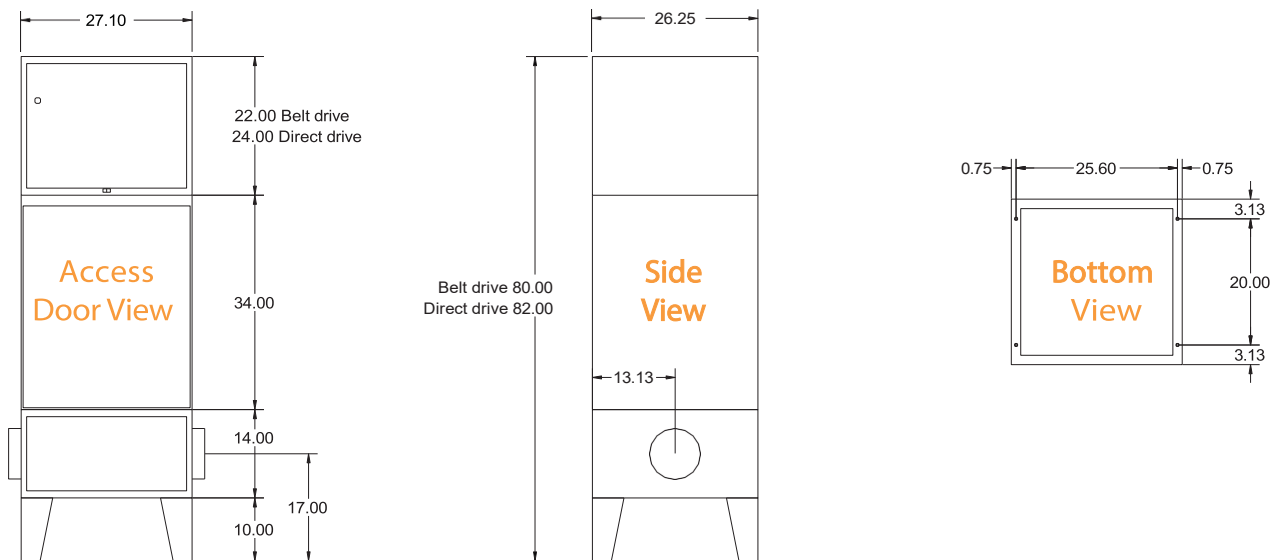

*All measurements in inches

Specifications

Airflow	4,000 CFM	
Cabinet	16 gauge steel cabinet with powder coated chemical resistant baked enamel with ivory textured finish	
Power Input	208–240 VAC, 60 Hz, 3 ph 440–480 VAC, 60 Hz, 3 ph	<i>International voltages available</i>
Motor Options	3 HP, 5 HP, 7-1/2 HP, 10 HP, 15 HP <i>Custom motors selected per application</i>	<i>Motor-blower packages sold separately</i>
Blower Options	Direct-drive, backward-inclined <i>Custom blowers selected per application</i>	
Filter Options: Prefilter	24" x 24" x 2" mist impingers 24" x 24" x 4" pleated prefilter MERV 8	24" x 24" x 4" pleated prefilter MERV 11 <i>Quantity determined based on application</i>
Filter Options: Primary (2 per unit)	24" x 24" x 26" MERV 14 bag filter 24" x 24" x 26" MERV 13 bag filter	24" x 24" x 12" polypropylene ESF MERV 14 24" x 24" x 12" polypropylene ESF MERV 13
Accessories	45 lbs. odor module(s) HEPA filter modules Additional pre-filtration	Wall mount arm Silencer
Weight	2 stage (w/o HEPA): 600 lbs. installed; 640 lbs. shipping	3 stage (with HEPA): 830 lbs. installed; 875 lbs. shipping
Features and Benefits	<ul style="list-style-type: none"> • Variety of motor and blower configurations to handle a wide range of applications • Optional silencer for applications that demand quiet operation • Dirty filter gauge for easy monitoring of filter status • Inlet flange for attaching ductwork 	<ul style="list-style-type: none"> • Standard size prefilter and main filter track size allows for the use of a variety of filter media for a wide range of applications • Drain connection to return collected oil/coolant back to the machine tool or to collect anything that drains off the filters in the air cleaner

Specifications subject to change without notice

Dimensions*

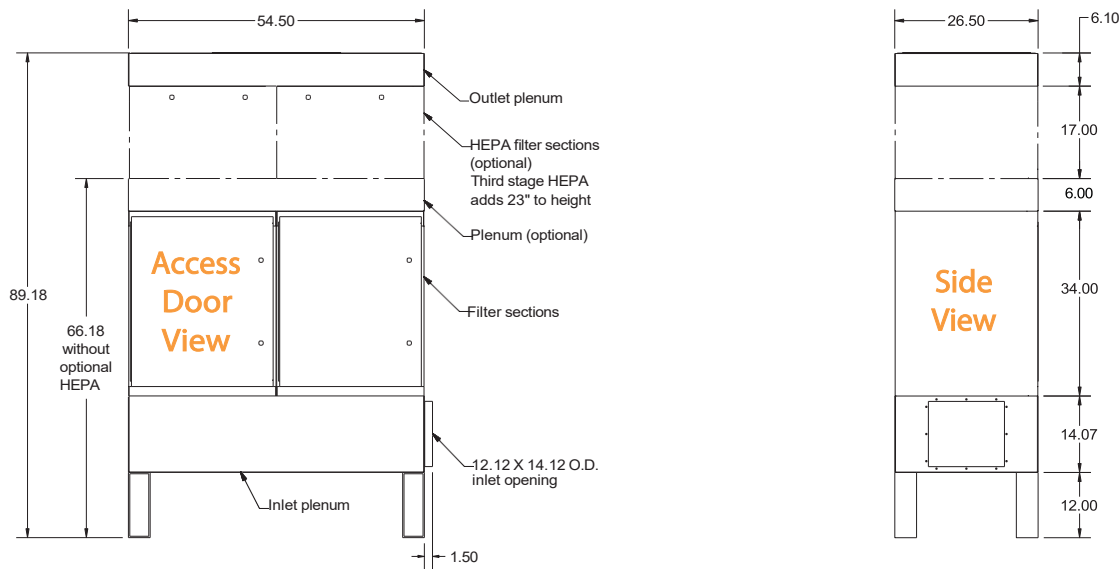

*All measurements in inches

This unit is to be used exclusively for source control in industrial applications in California.

Specifications

Airflow	6,000 CFM	
Cabinet	16 gauge steel cabinet with powder coated chemical resistant baked enamel with ivory textured finish	
Power Input	208–240 VAC, 60 Hz, 3 ph 440–480 VAC, 60 Hz, 3 ph	<i>International voltages available</i>
Motor Options	3 HP, 5 HP, 7-1/2 HP, 10 HP, 15 HP <i>Custom motors selected per application</i>	<i>Motor-blower packages sold separately</i>
Blower Options	Direct-drive, backward-inclined <i>Custom blowers selected per application</i>	
Filter Options:	24" x 24" x 2" mist impingers	24" x 24" x 4" pleated prefilter MERV 11
Prefilter	24" x 24" x 4" pleated prefilter MERV 8	<i>Quantity determined based on application</i>
Filter Options:	24" x 24" x 26" MERV 14 bag filter	24" x 24" x 12" polypropylene ESF MERV 14
Primary (3 per unit)	24" x 24" x 26" MERV 13 bag filter	24" x 24" x 12" polypropylene ESF MERV 13
Accessories	45 lbs. odor module(s) HEPA filter modules Additional pre-filtration	Wall mount arm Silencer
Weight	2 stage (w/o HEPA): 890 lbs. installed; 950 lbs. shipping	3 stage (with HEPA): 1,240 lbs. installed; 1,300 lbs. shipping
Features and Benefits	<ul style="list-style-type: none"> • Variety of motor and blower configurations to handle a wide range of applications • Optional silencer for applications that demand quiet operation • Dirty filter gauge for easy monitoring of filter status • Inlet flange for attaching ductwork 	<ul style="list-style-type: none"> • Standard size prefilter and main filter track size allows for the use of a variety of filter media for a wide range of applications • Drain connection to return collected oil/coolant back to the machine tool or to collect anything that drains off the filters in the air cleaner

Specifications subject to change without notice

Dimensions*

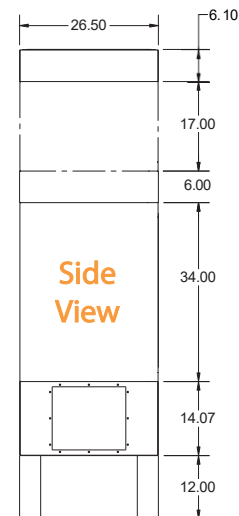
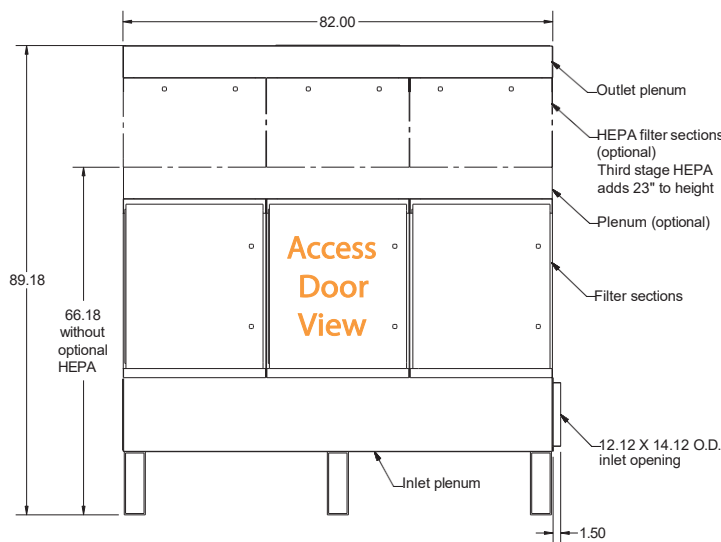

This unit is to be used exclusively for source control in industrial applications in California.

*All measurements in inches

Specifications

Airflow	8,000 CFM	
Cabinet	16 gauge steel cabinet with powder coated chemical resistant baked enamel with ivory textured finish	
Power Input	208–240 VAC, 60 Hz, 3 ph 440–480 VAC, 60 Hz, 3 ph	<i>International voltages available</i>
Motor Options	3 HP, 5 HP, 7-1/2 HP, 10 HP, 15 HP <i>Custom motors selected per application</i>	<i>Motor-blower packages sold separately</i>
Blower Options	Direct-drive, backward-inclined <i>Custom blowers selected per application</i>	
Filter Options:	24" x 24" x 2" mist impingers	24" x 24" x 4" pleated prefilter MERV 11
Prefilter	24" x 24" x 4" pleated prefilter MERV 8	<i>Quantity determined based on application</i>
Filter Options:	24" x 24" x 26" MERV 14 bag filter	24" x 24" x 12" polypropylene ESF MERV 14
Primary (4 per unit)	24" x 24" x 26" MERV 13 bag filter	24" x 24" x 12" polypropylene ESF MERV 13
Accessories	45 lbs. odor module(s) HEPA filter modules Additional pre-filtration	Wall mount arm Silencer
Weight	2 stage (w/o HEPA): 1,195 lbs. installed; 1,268 lbs. shipping	3 stage (with HEPA): 1,655 lbs. installed; 1,728 lbs. shipping
Features and Benefits	<ul style="list-style-type: none"> • Variety of motor and blower configurations to handle a wide range of applications • Optional silencer for applications that demand quiet operation • Dirty filter gauge for easy monitoring of filter status • Inlet flange for attaching ductwork 	<ul style="list-style-type: none"> • Standard size prefilter and main filter track size allows for the use of a variety of filter media for a wide range of applications • Drain connection to return collected oil/coolant back to the machine tool or to collect anything that drains off the filters in the air cleaner

Specifications subject to change without notice

Dimensions*

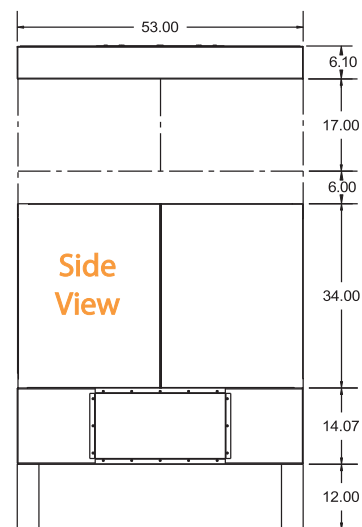
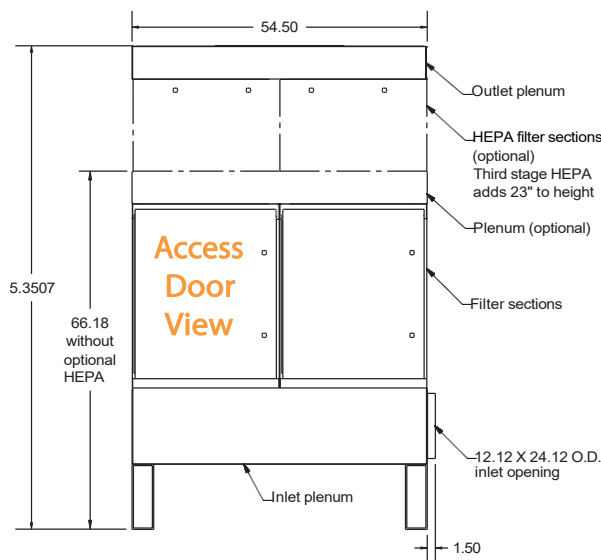

This unit is to be used exclusively for source control in industrial applications in California.

*All measurements in inches

The Original MistBuster®

Proudly designing and manufacturing the MistBuster source collection and MX-Series centralized filtration product lines for delivery in the United States and worldwide.



Tailored solutions from people who care

air-quality-eng.com
info@air-quality-eng.com

763-531-9823
800-328-0787

7140 Northland Drive N.
Minneapolis, MN
55428-1520, USA