

M66 R&L Media Air Cleaner with Source Capturing

Supplying Clean Air to Industry

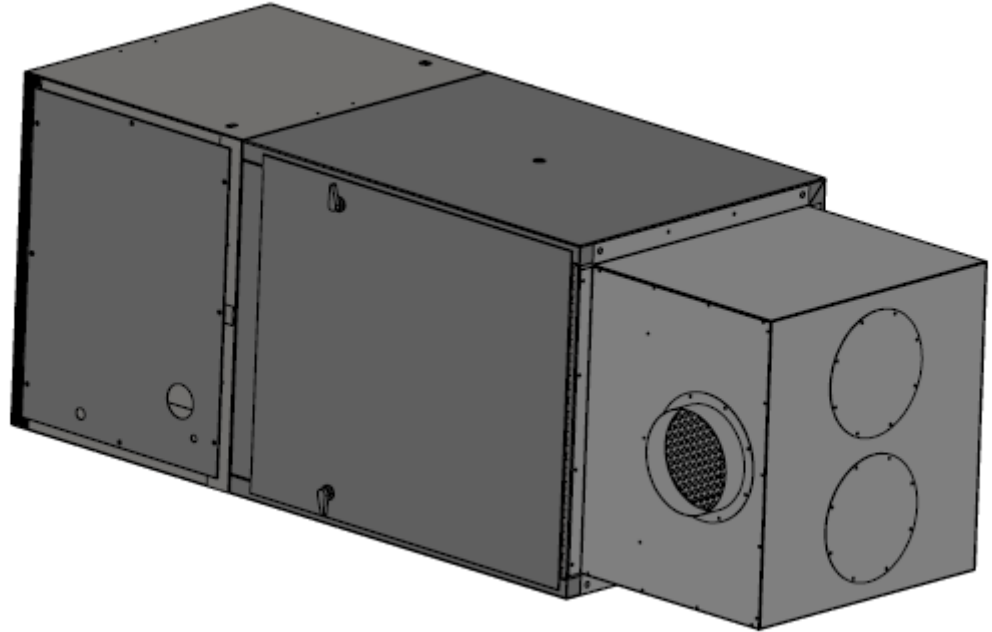

The M66 is a self-contained media air cleaning system designed for source capture applications. The M66 can be ordered with a three-stage filtration which will effectively remove a broad range of airborne contaminants including fine dusts, smoke, soot, vapors, mist, VOC's and more at a rate of up to 3200 CFM.



**AIR QUALITY
ENGINEERING**

Air Quality Engineering, founded in 1973, is proud to offer a continued, superior level of experience in manufacturing complete air filtration systems that provide the highest performance, efficiency, and capacity for the money. Our sales and engineering team's mission is to identify the most cost-effective, high-quality solutions for our customers' needs, whether commercial, industrial or residential.

M66 R&L FEATURES & SPECIFICATIONS:

DIMENSIONS: 27 1/8" H x 26 1/2" W x 56" L

WEIGHT: 280 lbs. installed
330 lbs. shipping weight

CABINET: 16-gauge welded steel cabinet with baked enamel textured coated finish.

POWER INPUT:

Voltage	Phase	1 HP Amps	2 HP Amps	3 HP Amps
110-120	1	12	NA	NA
208-240	1	6.6	9	NA
208-240	3	NA	NA	9
440-480	3	NA	NA	4.4

PRIMARY FILTER: 24" x 24" x 22", 8 pocket, 66 sq. ft. of synthetic media.
Optional filters can increase filter media to 200 sq. ft.

AIRFLOW/EFFICIENCY:

Stock Number	Filter	CFM = Cubic Feet Per Minute		
		1 HP	2 HP	3 HP
41072	95% Bag	1940 CFM	2620 CFM	3020 CFM
41056	85% Bag	2030 CFM	2675 CFM	3150 CFM
41055	65% Bag	2150 CFM	2800 CFM	3170 CFM
41057	50% Bag	2190 CFM	2830 CFM	3200 CFM
41061	35% Bag	2210 CFM	2850 CFM	3225 CFM

AMBIENT TEMP: 175° F Maximum

MOUNTING: Standing or hanging cabinet with horizontal airflow. Ceiling mount brackets – standard.

PREFILTER: 30-35% efficient pleated filters, 24" x 24" x 4". Filter media is a cotton and synthetic blend. Total prefilter media area is 29.5 ft.

MOTOR: 1 hp on single phase, 3 hp on three phase sealed ball bearings and thermally protected. Adjustable motor sheave allows for field adjustments to the rated airflow.

BLOWER: Forward curved, ball bearing, belt driven centrifugal blower. This blower is capable of moving 4400 CFM free air. Direct drive, backwards inclined blowers also available.

INSTRUMENTATION: **Dirty Filter Gage** – Factory installed pressure gage designed to determine filter replacement cycle.
Indicator Light – Light indicates that the blower motor is energized properly.

SOURCE CAPTURE: A plenum that can fit various flanges and hose sizes will be included.

FILTER ACCESS: Side load track system with hinged access door.

SOUND LEVELS: 70 dBA at 15 ft., 73 dBA at 9 ft.

STANDARD FEATURES:

- 36-month parts warranty.
- Dirty filter gauge.
- 10 ft. power cord with molded plug.
- Completely prewired including 3 phase.
- Custom Plenum, ducting, and hood accessories

OPTIONAL ACCESSORIES:

- 2, 3 and 5 HP BI blower packages
- Silencer.
- Extended service filters.
- HEPA and electrostatic add-on modules.
- Wrap around prefilter.
- Minihelic® filter gauge.
- 45 or 90 lbs of activated carbon
- Impinger assembly
- Oil mist bag filter
- 65% pre filter

M66L SHOWN WITH OPTIONAL 45 LB. CARBON MODULE & E.S.F. FILTER

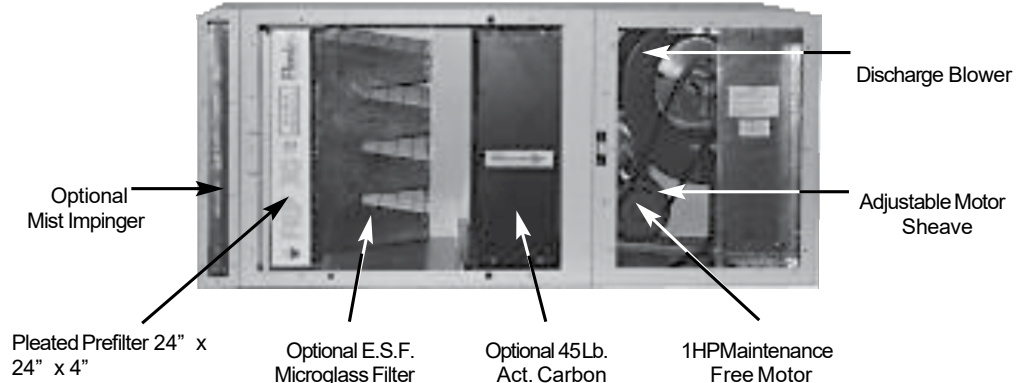

Specifications subject to change without notice.

This unit is to be used exclusively for source control in industrial applications in California.