

SMOKEMASTER®

M67 OWNER'S MANUAL

INDUSTRIAL MECHANICAL AIR CLEANER

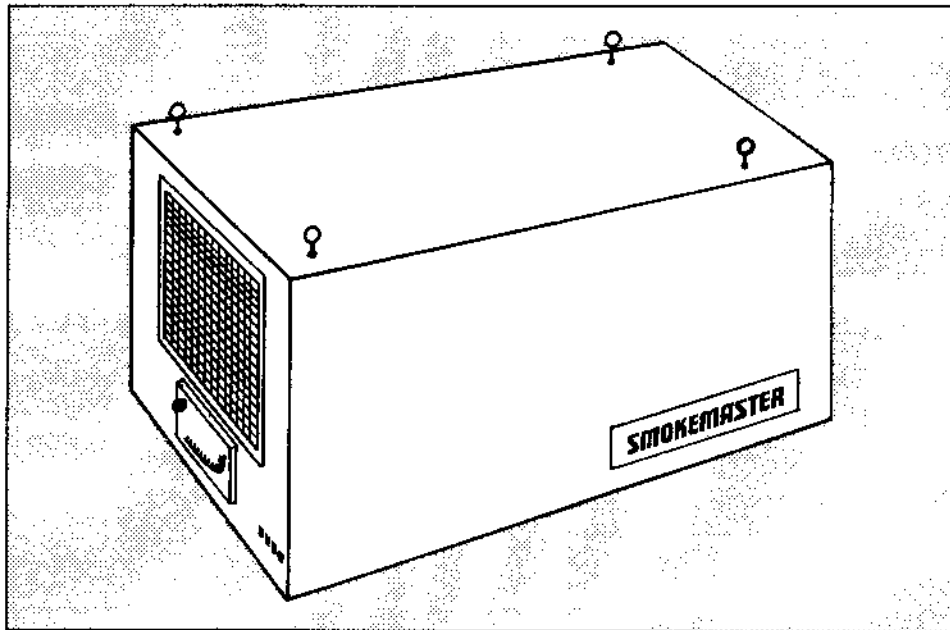

THE SMOKEMASTER M67 MECHANICAL AIR CLEANER CAPTURES DUST, SMOKE, SAW-DUST AND OTHER AIRBORNE POLLUTANTS IN THE WORK PLACE. THE M67 IS A COMPLETE SELF-CONTAINED AIR CLEANER DESIGNED TO HANG FROM THE CEILING FOR EFFICIENT AND ECONOMICAL AIR CLEANING WHERE SOURCE CAPTURING OF THE POLLUTANTS IS NOT POSSIBLE OR PRACTICAL.

- * FILTER CONFIGURATIONS AVAILABLE TO PROVIDE UP TO 95% EFFICIENCY
- * ALL MODELS ALLOW FOR 2 OR 3 STAGE FILTRATION
- * HEAVY DUTY 3/4 HP, 3-SPEED MOTOR WITH A 10" x 10" DIRECT DRIVE BLOWER WHICH DELIVERS MAXIMUM AIR FLOW
- * FACTORY INSTALLED PRESSURE GAUGE PROVIDES FILTER STATUS AT A GLANCE
- * PERMANENTLY LUBRICATED BALL BEARING MOTOR REQUIRES NO MAINTENANCE
- * MODELS AVAILABLE IN 120V AC OR 230V AC, 60 HZ. ALL MODELS INCLUDE AN 8 FOOT POWER CORD WITH MOLDED PLUG
- * ALL MODELS HAVE 4-WAY ADJUSTABLE LOUVERS TO DIRECT AIRFLOW

TABLE OF CONTENTS

SPECIFICATIONS	3
PLANNING THE INSTALLATION	
LOCATION DRAWINGS	4
SIZING	5
INSTALLATION	6
CHECK OUT AND OPERATION	7
MAINTENANCE	7
FILTER	7
AIR FILTER GAUGE	7
M67 WIRING SCHEMATIC	8
TROUBLESHOOTING	9
SERVICE	9
PARTS LIST	10
WARRANTY	11

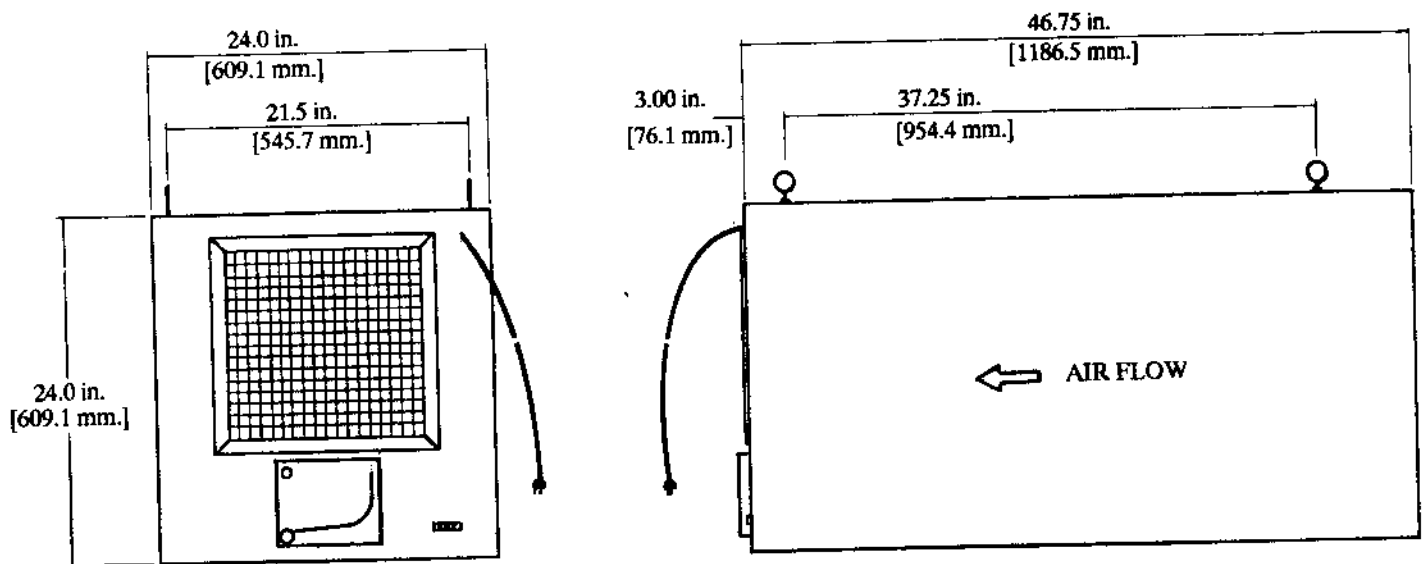

Fig. 1 - M67 dimensions in inches [mm in brackets]

SPECIFICATIONS

IMPORTANT

THE SPECIFICATIONS GIVEN IN THIS PUBLICATION DO NOT INCLUDE NORMAL MANUFACTURING TOLERANCES. THEREFORE, THIS UNIT MAY NOT MATCH THE LISTED SPECIFICATIONS EXACTLY. ALSO, THIS PRODUCT IS TESTED AND CALIBRATED UNDER CLOSELY CONTROLLED CONDITIONS; SOME MINOR DIFFERENCES IN PERFORMANCE CAN BE EXPECTED IF THOSE CONDITIONS ARE CHANGED.

MODEL:	M67B1003	M67B1011
VOLTAGE:	120VAC 1 Phase	208-240VAC 1 Phase
FREQUENCY:	50/60 Hz	50/60 Hz
CURRENT MAXIMUM: (High Speed Free Air)	7.3 Amps	4.0 Amps
POWER MAXIMUM: (High Speed Free Air)	970 Watts	970 Watts
SHIPPING WEIGHT:	160 Lbs. (73 Kg.)	160 Lbs. (73 Kg.)
INSTALLED WEIGHT:	119 Lbs. (54 Kg.)	119 Lbs. (54 Kg.)

MOTOR: 3/4 HP, PSC, with sealed ball bearings

AMBIENT TEMPERATURE RATING: The operating temperature range is -40° F to 104° F (-40° C to 220° C)

CAPACITY (CFM):

	HIGH	MEDIUM	LOW
95% BAG	1625	1400	1250
85% BAG	1690	1530	1285
65% BAG	1775	1605	1300
50% BAG	1950	1655	1310
35% CUBE	1980	1705	1380

DIMENSIONS: See Fig. 1, page 2

BLOWER: Direct drive, forward curve, 10" diameter x 10" width

NOISE LEVELS:
(dBA)

	3'	6'	9'	12'	15'
HIGH	73	72	71	69	68
MED	71	71	70	68	67
LOW	68	68	67	66	64

Does not meet California air cleaner regulation requirements; cannot be shipped to California.

LOCATION DRAWINGS

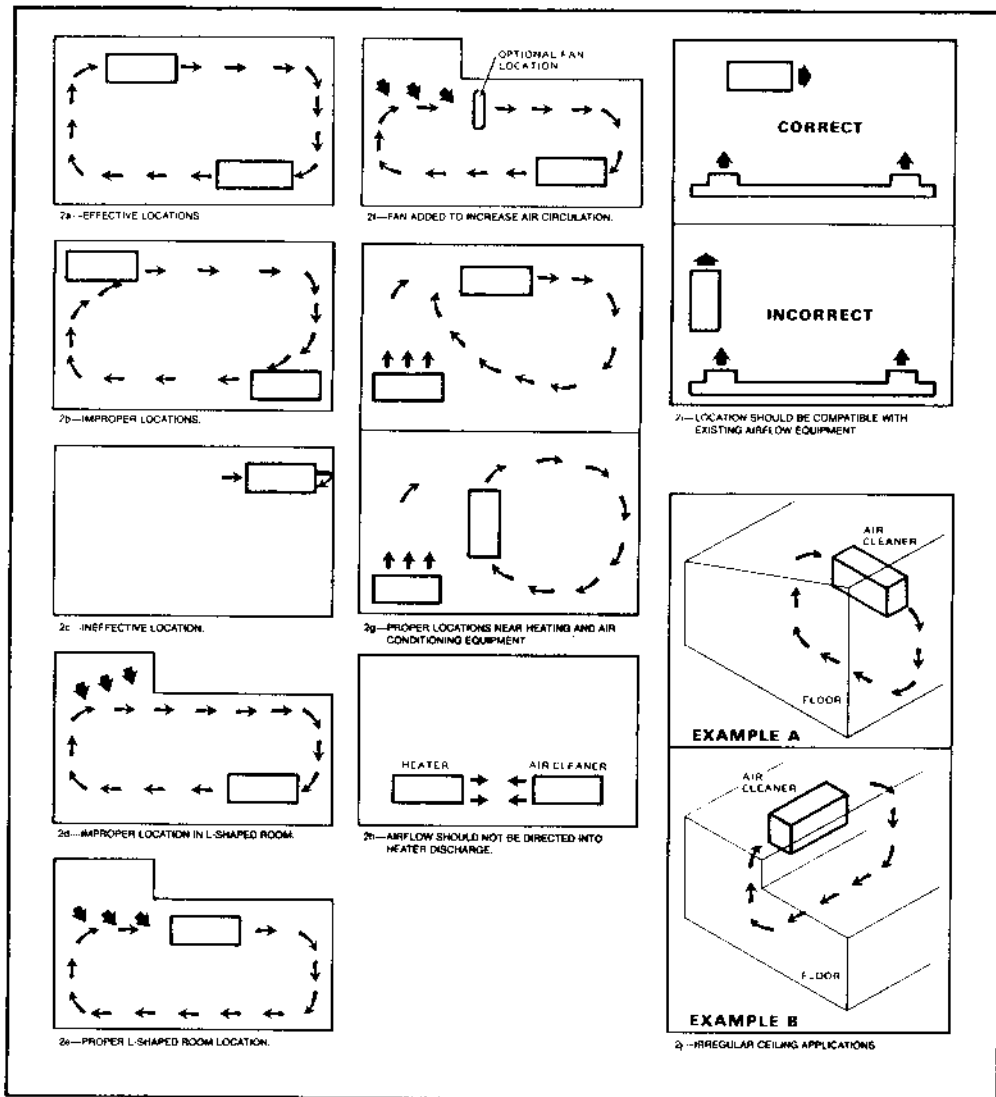

Fig. 2 - Guidelines for locating the M67 when ambient cleaning

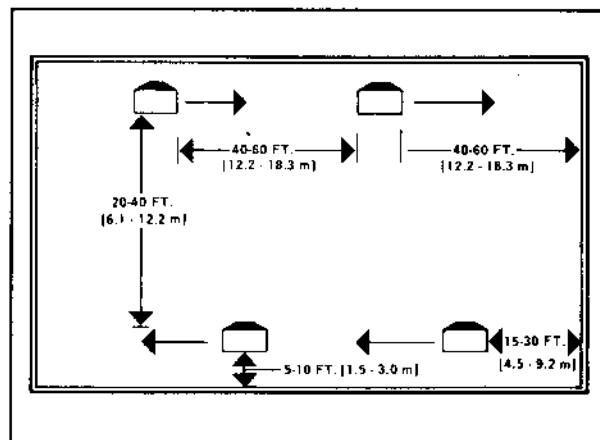

Fig. 3 - M67 location guide for background cleaning

WARNING

The M67 is not explosion proof. It must NOT be installed where there is potential for contact with explosive dusts, gases or vapors.

INTRODUCTION

Clean air is the subject of numerous laws and regulations. Typical requirements in the United States are those put out by the Occupational Safety and Health Administration (OSHA). Private groups, such as the American Society of Heating, Refrigeration and Air Conditioning Engineers (ASHRAE), have also published numerous recommendations.

Normally, clean air is defined in regulations and recommendations as air having a limited amount of contaminant in it; commonly expressed as parts per million, or milligrams per cubic meter. Counteractions are intended to lower or eliminate the amount of contaminants in the air. One of the more common methods of achieving this goal is through the use of self-contained air cleaners.

Contact your Air Quality Engineering representative for assistance in determining the correct application of air cleaners.

SIZING

Sizing is that part of the installation which determines how many air cleaning units are required to maintain a desired level of air quality. The process of sizing an application involves roughly calculating the number of air cleaners needed and then modifying the calculation according to the specific characteristics of each application.

For background air cleaning, the number of air cleaners needed can be estimated by the relationship of air volume to the needed air changes per hour. In these cases the following formula is helpful:

$$\frac{\text{Air Cleaners} = \text{Air Volume} \times \text{Air Changes/Hour}}{\text{Clean Air Rating} \times 60}$$
$$\text{Clean Air Rating} = \text{Airflow} \times \text{Efficiency}$$

The air volume in a space is sometimes reduced to account for high ceilings and large equipment in the space. For example, in an application where the ceiling is higher than 30 ft. [9.1 m], the air volume above 30 ft. [9.1 m] may be subtracted if it does not significantly affect contaminant dispersal either by how the contaminants are circulated from their sources or how the heating, cooling or ventilating equipment affects the dispersment of the contaminants. Also, if equipment takes up a great deal of space in relation to the total air space, its volume may be deducted from the total air volume.

A method for calculating the needed air changes per hour is to measure the generation rate of the contaminants and the suggested allowable level of contamination. To use this method of calculation, consult your Air Quality Engineering representative.

Regardless of the method used to calculate the number of units needed to produce clean air, the physical conditions of the space to be cleaned may either limit this number or demand that more units be installed. For background air cleaning it is important to establish a uniform airflow pattern throughout the entire space.

Limitations to the calculated sizing may be a lack of space for mounting areas or the number of units may interrupt normal building operation; that is, a unit cannot be mounted where an overhead crane will smash into it or where stand mountings seriously interrupt building traffic patterns. The number of units required by air volume and air changes per hour might need to be increased when the shape of a structure is such that effective capturing and air distribution is not possible according to the sizing calculations.

WARNING

Do not use general background air cleaning for toxic substances unless appropriate auxiliary respiratory protection is used.

AMBIENT CLEANING/BACKGROUND

Whether an air cleaner is ceiling hung or placed on a stand, the first important consideration is that the inlet of the unit be located as close as is reasonably possible to the greatest concentration of air contaminants. Second, since the air cleaner draws contaminated air from approximately 10 ft. [3.0 m] around the inlet, and exhausts the cleaned air from 50 to 75 ft. [15.2 to 22.8 m] from the outlet, the inlet of the unit should be placed 25 percent of the distance along the wall of a room. See Fig. 3.

DO NOT locate an air cleaner inlet too close to the corners of a room. Contaminated air will be able to bypass the unit and not be cleaned. DO NOT locate an air cleaner outlet too close to a corner or wall. See Fig. 2c. The cleaned air will recirculate directly back to the air cleaner inlet.

DO NOT locate an air cleaner in an L-shaped room so that exhausted air enters directly into the small portion of the room, as shown in Fig. 2d. This can produce a self-contained circular air pattern in the small part of the room which decreases the air cleaner's effectiveness. Locate an air cleaner in an L-shaped room as indicated in Fig. 2e.

The shape of a room and location restrictions may require the installation of a fan, as in Fig. 2f, to promote proper air circulation. Also, the size of a room may require the use of fans to bring contaminants to an air cleaner inlet.

In rooms with irregular ceilings, install the air cleaner close to the ceiling on the highest wall, as Example A indicates in Fig. 2j. When one section of the ceiling is at least 12 in. [304 mm] higher than another, locate the air cleaner in the area with the higher ceiling, as shown in Example B of Fig. 2j.

When selecting locations for numerous units, position the air cleaners to create uniform movement of air and provide maximum access to the sources of contamination. The outlets of the air cleaners should not be located so that they generate opposing air currents or that the outlet from one air cleaner is less than 30 ft. [9.1 m] from the inlet of another air cleaner.

INSTALLATION

WHEN INSTALLING THIS PRODUCT.....

1. Read these instructions carefully. Failure to follow them could damage the product or cause a hazardous condition.
2. Check the ratings given in the instructions and on the product to make sure the product is suitable for your application.
3. Installer must be a trained, experienced service technician.
4. After installation is complete, check out air cleaner operation as provided in these instructions.

CAUTION

Motor is equipped with automatic thermal overload protection. Should the motor become overloaded, it will de-energize. However, it automatically energizes after sufficient cooling time (several minutes to an hour). Therefore, be sure to turn off air cleaner before servicing.

The M67 was designed for ease of installation. The M67 air cleaner can be installed overhead using chain or rod. The air cleaner can also be mounted to a stand or cart as well as to a wall. For maximum air cleaner efficiency, refer to Fig. 2 guidelines for locating the M67 for ambient cleaning.

NOTE: THE INSTALLATION MUST CONFORM TO ALL LOCAL ORDINANCES, BUILDING AND ELECTRICAL CODES.

OVERHEAD MOUNTING

When installing the M67 in an overhead location, position the air cleaner as close to the contaminant source as possible. This increases the air cleaner's effectiveness. It is important to select an overhead mounting location which provides easy access to the M67 inlet for filter replacement and maintenance.

The overhead structure must be strong enough to support twice the weight of the M67. Do not fasten the air cleaner to a false ceiling or to plaster or plasterboard. In some cases it may be necessary to construct supports which will bear the weight of the M67.

Install the M67 using the 3/8" eye bolts provided with the air cleaner. Refer to Fig. 1, page 2, for the spacing of the eye bolts. Be certain that the mounting apparatus (not included) from the eye bolts to the ceiling provides adequate strength and stability. The mounting apparatus must be attached securely to the overhead structure. The M67 must be supported by all four eye bolts. See Fig. 4.

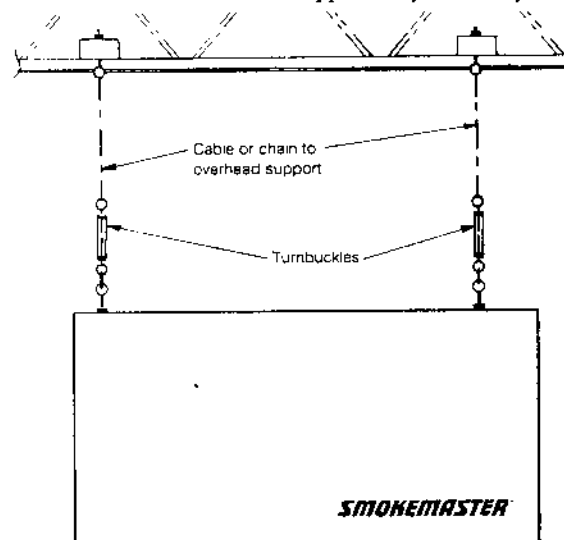

Fig. 4 - M67 chain hung

STAND MOUNTING

Securely mount the M67 on an appropriate stand or cart. Locate as close to the contaminant source as possible. The location should also allow satisfactory distribution of air from the outlet of the air cleaner.

NOTE: DIFFERENT SOURCE CAPTURE UNITS MUST BE USED FOR TOXIC SUBSTANCES.

ELECTRICAL INSTALLATION

CAUTION

All wiring must comply with applicable codes and ordinances. Verify that the electrical rating on the M67 is compatible with the power supplied to the air cleaner.

The M67 air cleaner is completely wired and operationally checked at the factory. The M67 comes with an 8 foot power cord and molded plug. There must be a standard grounded outlet provided within 8 feet of the air cleaner. Route the power cord so that it will be out of the way of the building's occupants. Do not use an extension cord.

CHECK OUT

Before operating the M67, check out the installation using the following procedures:

1. Observe that the air cleaner is oriented for good air circulation; it will not interfere with personnel and material traffic. Keep out of fire lanes and away from overhead cranes.
2. Clean up the inside of the cabinet, the outside of the cabinet, and the installation area.
3. The odor neutralizer cartridge is enclosed in a plastic bag. The bag should be removed after the M67 is installed. For strong odors, open both control dials to the maximum opening.
4. Check that the filters are correctly oriented; the airflow arrows on the filter are pointing toward the blower and the filter retainer rods are in place.
5. Check that the filter change gauge (manometer) is level, see spirit level in the right hand corner of the gauge.
6. Check the oil level, in the filter change gauge, and adjust the zero knob so that the oil level is at "0 inches of water" when the M67 is turned off.
7. Adjust discharge grille to direct airflow as desired.

OPERATION

When the M67 is energized, the blower produces an airflow which directs contaminated air into the air cleaner inlet. The large particulate is caught in the prefilter. Particles too small to be caught in the prefilter are then drawn into the primary filter. The clean air is then blown back into the room through the exhaust grille. See Fig. 6 on page 8.

WITH PREFILTER AND PRIMARY FILTER IN PLACE.....

1. Turn the air cleaner on by pressing the control switch for low, medium or high blower speed. Check that the blower is providing a strong discharge.
2. Check the reading on the filter change gauge. The reading on the new filters should be between .30 in. W.C. and .60 in. W.C. depending upon the filters being used.

MAINTENANCE

CAUTION

1. Do not place a ladder against the M67 when it is mounted in an overhead position. A lift platform should be used to gain access to the air cleaner for filter removal and servicing.
2. The M67 cabinet was designed to support only the weight of the internal components; motor, blower and filters. Do not climb in or on the air cleaner. Failure to heed this warning could result in damage to equipment or bodily injury.
3. Disconnect power to the M67 before working on or near the air cleaner.

FILTER MAINTENANCE/REPLACEMENT

Dirty air passes through the prefilter. Large particulate, such as lint, is removed by the prefilter. The remaining smaller particulate is then captured by the primary filter.

As the contaminant load on the filters increases, the filters become more efficient in capturing the smaller particles. At the same time, however, the dirty filter allows less air to pass through, resulting in less particle collection and a decrease in the overall effectiveness of the air cleaner.

The M67 air cleaner is equipped with a pressure gauge which indicates the restriction to air flow caused by the filters loading with particulate. When the gauge indicates 1.0 in. W.C. on high speed, or a significant reduction of airflow is noticed, follow the steps in the next column:

1. To remove prefilter, remove prefilter retaining rod and remove prefilter. If the particulate is dry, the standard 2" prefilter can be cleaned by shaking or vacuuming. If the prefilter does not come clean after vacuuming, or is saturated with oil, the prefilter should be replaced.
2. If no performance improvement is evident after cleaning or replacing the prefilter, the primary filter will have to be replaced. In most cases, the prefilter can be replaced several times before the primary filter will need to be replaced.
3. If the optional carbon filter is being used, it should be checked to insure that it is not plugged with dirt, causing reduced airflow. This carbon filter should be replaced every six months at a minimum.
4. The odor neutralizer cartridge should be replaced every 60 days. This cartridge is located behind the primary filter. It is held in place by a plastic clip; it requires no tools to remove it from the air cleaner.

AIR FILTER GAUGE MAINTENANCE

Check oil level occasionally and adjust zero knob as required. Be sure the M67 is turned off before adjusting zero knob. Add oil only when necessary. Use Dwyer Red Oil only; other fluids may damage the gauge. Clean with a soft cloth using a little pure soap and water. Use of a small brush will aid in cleaning the knobs. Avoid cleaning fluids and liquid soaps, which may have chlorinated solvents in them, as they may damage the gauge.

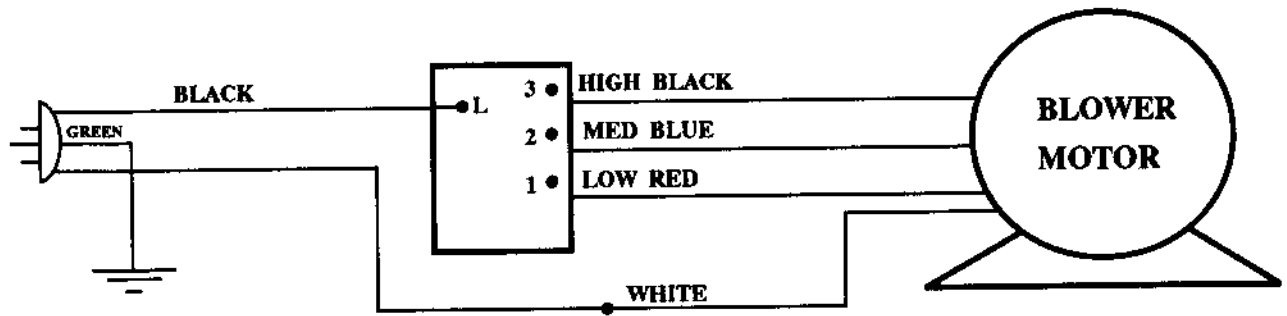

Fig. 5 - Schematic diagram for single phase M67 air cleaner

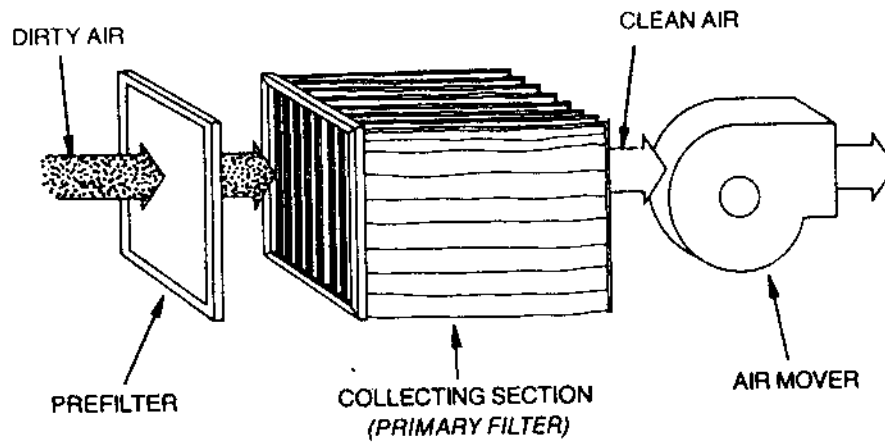

Fig. 6 - Operation

TROUBLESHOOTING

WARNING

The following instructions are intended for qualified service personnel only. Dangerous line voltage circuits and rotating parts are exposed during these procedures. Always disconnect power to the air cleaner before servicing.

SYMPTOMS	CAUSE	SOLUTION
1. Air cleaner motor will not run on Low, Medium or High.	A. No power to the air cleaner. B. Bad control switch. C. Bad motor capacitor. D. Bad motor.	A. Check power source/Circuit breaker/fuse B. Replace switch. C. Replace motor capacitor. D. Replace motor.
2. Motor starts, stops, restarts.	A. Motor overloads, trips out thermal overload protector in the motor. B. Temperature exceeds 120° F.	A. Too much airflow--make sure all filters are in place. B. Reduce ambient temperature.
3. Low efficiency /full airflow.	A. Filter efficiency too low.	A. Select higher efficiency bag.
4. Reduced airflow.	A. Dirty filters. B. Blower wheel is loose on motor.	A. Replace filters. B. Tighten setscrew on motor shaft.

SERVICE

All the electrical components, motor, motor capacitor and switch are mounted to the outlet panel along with the blower. If it becomes necessary to replace one of these components, the outlet panel will have to be removed from the M67 cabinet. See Fig. 7

CAUTION

The fully assembled outlet panel weighs approximately 50 lbs. The M67 should be placed on a bench before removing the outlet panel. Wear gloves to protect hands when removing the outlet panel.

TO REMOVE THE OUTLET PANEL.....

1. Remove the plastic filter gauge. This will prevent damage during handling.
2. Maintain a firm grip on the outlet panel while removing the 16 screws. It is recommended that two people perform this operation.
3. Place the outlet panel on a bench with the blower facing in the upward position. This will give full access to electrical components and wiring.

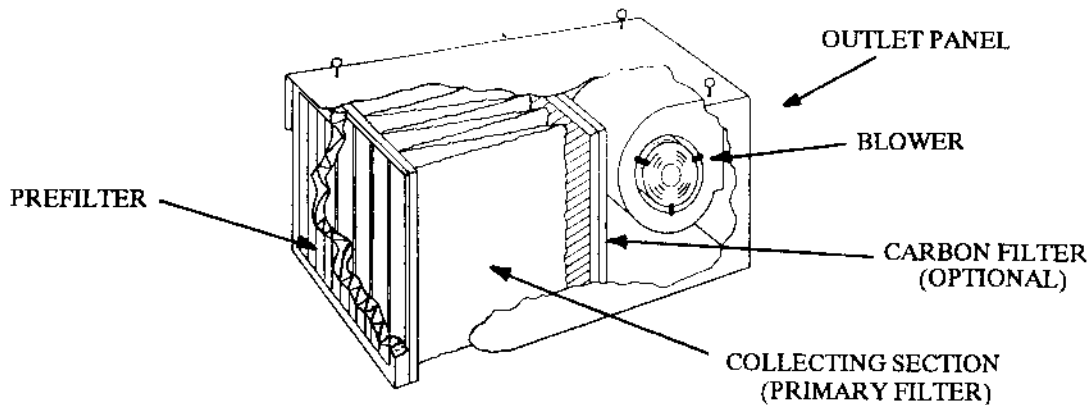

. Fig. 7

PARTS LIST

MODEL	M67B1003	M67B1011
SWITCH	10110	10110
FILTER GAUGE	10205	10205
GRILLE	30486	30486
BLOWER	37025	37025
MOTOR	40015	40016
CAPACITOR	40104	40103
FILTER RETAINING ROD	21236	21236
FILTER RETAINING ROD (POST)	21237	21237
ODOR NEUTRALIZER CARTRIDGE	07094	07094

	<u>PART #</u>	<u>EFFICIENCY</u>	<u>DESCRIPTION</u>	
PREFILTERS:	41053	35%	PLEATED	STANDARD
	41083		ALUMINUM MESH	OPTIONAL
PRIMARY FILTERS:	41072	95%	MULTI-POCKET BAG	
	41056	85%	MULTI-POCKET BAG	
	41055	65%	MULTI-POCKET BAG	
	41057	50%	MULTI-POCKET BAG	
	41061	35%	CUBE	
THIRD STAGE FILTERS:	41084	1/2"	CHARCOAL FILTER	
	41085	1"	CHARCOAL FILTER	
	41086	2"	CHARCOAL FILTER	

CERTIFICATE OF WARRANTY

THREE-YEAR LIMITED WARRANTY

Air Quality Engineering, Inc. (AQE), warrants to the original purchaser, subject to the conditions below, that if the "Product" covered by this warranty should fail to perform by reason of improper workmanship or material, AQE will during the period of three (3) years from the date of original purchase either (i) replace the product or (ii) provide all necessary parts to repair the product without charge. The decision to replace the product or the necessary parts shall rest solely with AQE. This three-year limited warranty does not apply to main filter elements. AQE will replace without charge the main filter elements during the period of thirty (30) days from the date of original purchase if the main filter elements fail to perform by reason of improper workmanship or material. This warranty is valid only under the following conditions:

CONDITIONS

1. **REGISTRATION:** The purchaser's completion and mailing of the Registration Card to Air Quality Engineering, Inc., 7140 Northland Drive North, Minneapolis, Minnesota 55428-1520 within 30 days of original purchase.
2. **AUTHORIZATION:** The purchaser will contact AQE at (763) 531-9823 for authorization, returned goods number (RGA) and the shipping address. AQE will direct the purchaser to either return the necessary parts or the product at AQE's option.
3. **PROPER DELIVERY:** The shipping, freight prepaid or delivery of the parts or the product to AQE in either its original carton or in a carton assuring similar protection of the product with the returned goods number (RGA) clearly displayed on the outside of the carton.
4. **UNAUTHORIZED REPAIR:** A showing by the original purchaser that the product has not been altered, repaired or serviced by anyone other than an authorized service technician using genuine AQE parts.
5. **UNAUTHORIZED PARTS:** A showing by the original purchaser that the product has had only genuine AQE parts and filters used in its operation and maintenance.
6. **SERIAL NUMBER INTACT:** A showing by the original purchaser that the serial number has not been altered or removed.
7. **MISUSE:** A showing by the original purchaser that the product has not been involved in an accident, freight damaged, misused, abused or operated contrary to the instructions contained in the Owner's Manual.

Air Quality Engineering, Inc.'s, sole responsibility shall be to repair or replace the product within the terms stated above. AQE SHALL NOT BE LIABLE FOR ANY CONSEQUENTIAL DAMAGES RESULTING FROM ANY BREACH OF WARRANTY, EXPRESS OR IMPLIED, APPLICABLE TO THIS PRODUCT. Some states do not allow the exclusion or limitation of consequential damages so this limitation may not apply to you.

THIS WARRANTY IS IN LIEU OF ALL OTHER WARRANTIES, EXPRESS OR IMPLIED, AND THE WARRANTIES OF MERCHANTABILITY AND FITNESS FOR A PARTICULAR PURPOSE ARE HEREBY EXCLUDED BEYOND THE THREE-YEAR DURATION OF THIS WARRANTY. Some states do not allow limitations on how long an implied warranty lasts so the above limitation may not apply to you.

This warranty gives you specific legal rights and you may also have other rights that vary from state to state.

**AIR QUALITY ENGINEERING, INC.
7140 NORTHLAND DRIVE NORTH
MINNEAPOLIS, MINNESOTA 55428-1520**

**TOLL FREE: 1-800-328-0787
TELEPHONE: (763) 531-9823
FAX: (763) 531-9900**

MANUFACTURER & WORLDWIDE DISTRIBUTOR OF SMOKEMASTER® AIR CLEANING SYSTEMS

