

Supplying Clean Air to Industry

MistBuster® 500, 850C, 850 and 2000 Installation and Operation Manual

Protected by U.S. Patent Numbers 6,428,611 and 7,717,984



Machine Mountable Mist & Smoke Collector



**AIR QUALITY
ENGINEERING**

Air Quality Engineering, founded in 1973, is proud to offer a continued, superior level of experience in manufacturing complete air filtration systems that provide the highest performance, efficiency, and capacity for the money. Our sales and engineering team's mission is to identify the most cost-effective, high-quality solutions for our customers' needs, whether commercial, industrial or residential.

| | PAGE |
|--|------|
| MB500, MB850C AND MB850 SPECIFICATIONS | 3 |
| MB2000 SPECIFICATIONS | 4 |
| ELECTRICAL | 5-6 |
| START UP | 7 |
| ROUTINE MAINTENANCE | 7 |
| HEPA FILTER OPTION INSTALLATION | 8 |
| CELL PARTS | 8 |
| TROUBLESHOOTING | 9-11 |
| WARRANTY | 12 |

INSTALLATION

<https://www.air-quality-eng.com/installation-mistbusters/>

PARTS LIST

<https://www.air-quality-eng.com/parts-mistbusters/>

Air Quality Engineering Inc., has a policy of continuing product improvement and reserves the right to make changes in design and specification without notice.



**AIR QUALITY
ENGINEERING**

7140 Northland Drive North, Minneapolis, MN 55428, USA
PHONE: 763-531-9823 • TOLL FREE: 1-800-328-0787
EMAIL: info@air-quality-eng.com • www.air-quality-eng.com

- IMPORTANT -

THE SPECIFICATIONS GIVEN IN THIS PUBLICATION DO NOT INCLUDE NORMAL MANUFACTURING TOLERANCES. THEREFORE, THIS UNIT MAY NOT MATCH THE LISTED SPECIFICATIONS EXACTLY. ALSO, THIS PRODUCT IS TESTED AND CALIBRATED UNDER CLOSELY CONTROLLED CONDITIONS AND SOME MINOR DIFFERENCES IN PERFORMANCE CAN BE EXPECTED IF THOSE CONDITIONS ARE CHANGED.

| | |
|------------------------------------|--|
| DIMENSIONS MB500: | Cabinet – 27.13" L [690mm] x 15" W [381mm] x 17.25"H [438mm] See Fig.1 |
| DIMENSIONS MB850C: | Cabinet – 27.13" L [690mm] x 15" W [381mm] x 22.42" H [570mm] See Fig.1 |
| DIMENSIONS MB850: | Cabinet – 27.13" L [690mm] x 15" W [381mm] x 27.5" H [700mm] See Fig.1 |
| INLET OPENING: | 16.62" [422mm] x 9.08" [231mm]. See Fig. 3 |
| WEIGHT MB500: | 65 lbs [30kg] installed weight; 76 lbs [35kg] shipping weight. |
| WEIGHT MB850C: | 93 lbs [42kg] installed weight; 105 lbs [48kg] shipping weight. |
| WEIGHT MB850: | 99 lbs [45kg] installed weight; 111 lbs [50kg] shipping weight. |
| CABINET: | 16 gauge steel cabinet with chemical resistant baked enamel, textured finish |
| AIRFLOW MB500: | 500cfm [850cmh] @ 0.6"wg" [149Pa] top discharge |
| AIRFLOW MB850C & MB850: | 850cfm [1444cmh] @ 0.7"wg [174Pa] top discharge |
| EFFICIENCY: | Up to 99.9% efficiency on submicron particles per ASHRAE 52.2 standard |
| FILTRATION: | 1st Stage – 4" aluminum mesh impinger 2nd Stage – AQE Advantage® (Long Life) Electronic Cell 3rd Stage – MistBuster (High Efficiency) Cell 4th Stage – MistBuster (High Efficiency) Cell Final Stage – HEPA filter 99.97% efficiency or ESF Filter or Carbon Module |
| MB850C & MB850 ONLY | |
| MB850 ONLY OPTIONAL | |
| OPTIONAL | |
| POWER SUPPLY: | Self-regulating, dual voltage, solid-state power supply; two for MB850 |
| MOTORIZED IMPELLER: | Backward curved, vibration-free, direct drive rated at 710cfm@0"wg for MB500 and at 980cfm@0"wg for MB850C and MB850 |
| POWER: | 115 VAC, 60 Hz, 2.5 Amps OR 230 VAC, 60 Hz, 1.25 Amp for MB500 115 VAC, 60 Hz, 3.9 Amps OR 230 VAC, 60 Hz, 1.95 Amp for MB850C 115 VAC, 60 Hz, 4.3 Amps OR 230 VAC, 60 Hz, 2.15 Amp for MB850 |
| POWER CORD: | MistBuster Units are NOT Dual Voltage Ten-foot power cord with standard molded plug |

This unit is to be used exclusively for source control in industrial applications in California.

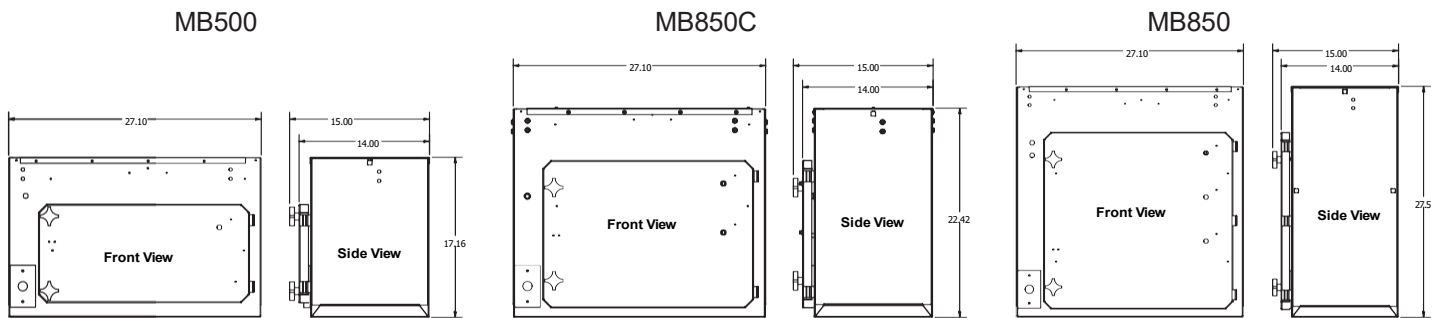

Figure 1

Air Quality Engineering Inc., has a policy of continuing product improvement and reserves the right to make changes in design and specification without notice.



7140 Northland Drive North, Minneapolis, MN 55428, USA
PHONE: 763-531-9823 • **TOLL FREE:** 1-800-328-0787
EMAIL: info@air-quality-eng.com • www.air-quality-eng.com

- IMPORTANT -

THE SPECIFICATIONS GIVEN IN THIS PUBLICATION DO NOT INCLUDE NORMAL MANUFACTURING TOLERANCES. THEREFORE, THIS UNIT MAY NOT MATCH THE LISTED SPECIFICATIONS EXACTLY. ALSO, THIS PRODUCT IS TESTED AND CALIBRATED UNDER CLOSELY CONTROLLED CONDITIONS AND SOME MINOR DIFFERENCES IN PERFORMANCE CAN BE EXPECTED IF THOSE CONDITIONS ARE CHANGED.

| | |
|----------------------------|---|
| DIMENSIONS: | Cabinet – 26"W x 27.56"D x 27.50"H. See Fig. 2. |
| INLET OPENING: | 20.75" x 16". |
| WEIGHT: | 203 lbs. installed weight; 230 lbs. shipping weight. |
| CABINET: | 16 gauge steel cabinet with a chemical resistant baked enamel, textured finish. |
| AIRFLOW: | 50-1650cfm @ 0.7"wg top discharge |
| EFFICIENCY: | Up to 99.9% efficiency on submicron particles per ASHRAE 52.2 standard test. |
| FILTRATION: | 1st Stage – 4" aluminum mesh impinger 2nd Stage – AQE Advantage® (Long Life) Electronic Cell 3rd Stage – MistBuster (High Efficiency) Cell 4th Stage – MistBuster (High Efficiency) Cell 5th Stage – HEPA filter 99.97% efficiency; ESF Filter; or Carbon Module |
| OPTIONAL | |
| OPTIONAL | |
| POWER SUPPLIES: | Two (optional third), independent, self-regulating, dual voltage, solid-state power supplies |
| MOTORIZED IMPELLER: | Two backward curved, vibration-free, direct drive rated at 980cfm @ 0"wg |
| POWER: | 115 Vac, 60 Hz, 8.2 Amps 230 Vac, 60 Hz, 4.1 Amps |
| POWER CORD: | Ten-foot power cord with standard molded plug |

This unit is to be used exclusively for source control in industrial applications in California.

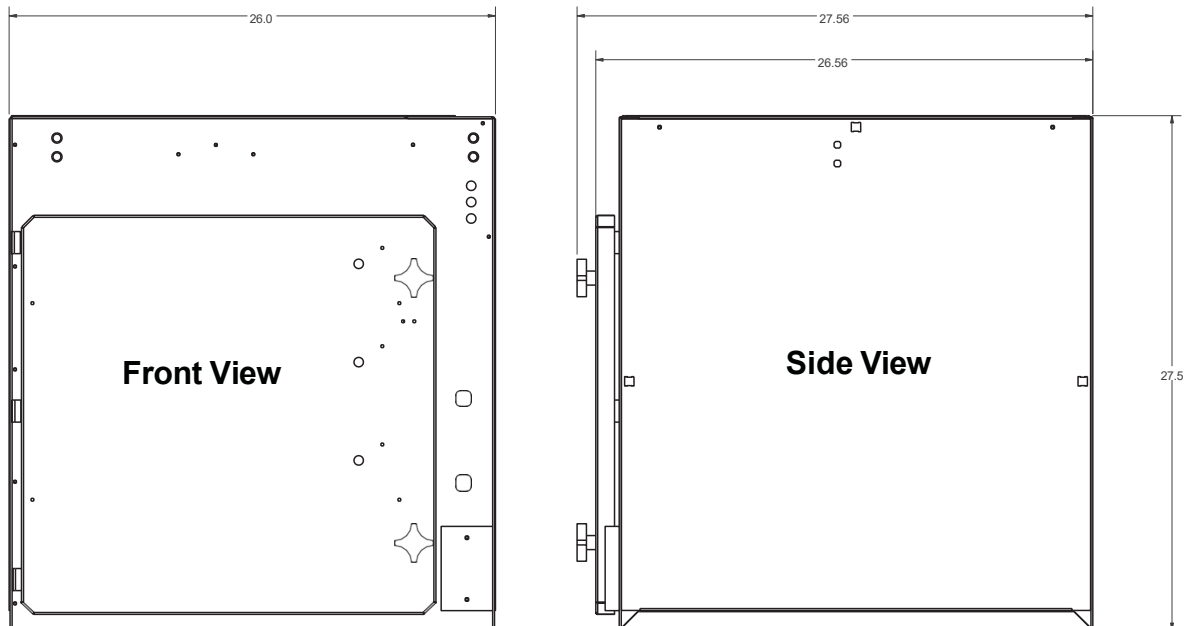

Figure 2

Air Quality Engineering Inc., has a policy of continuing product improvement and reserves the right to make changes in design and specification without notice.



7140 Northland Drive North, Minneapolis, MN 55428, USA
 PHONE: 763-531-9823 • TOLL FREE: 1-800-328-0787
 EMAIL: info@air-quality-eng.com • www.air-quality-eng.com

⚠ WARNING

All electrical work must be done by a qualified electrician and with accordance to local codes and regulations.

Be certain that the power source is compatible with the model ordered. See the rated voltage on the inside of the filter access door.

Proper grounding of the MistBuster is essential for safety and operation.

Cord Connected

The MistBuster is equipped with a 10-foot [3048mm] power cord with a standard molded (15 amp rated) plug. There must be a standard grounded outlet provided within 10 feet [3048mm] of the MistBuster. Route the power cord so that it is out of the way of the building's occupants and so that it does not interfere with the machine operation.

Conduit Connected

The MistBuster can be hard wired. **All wiring must comply with applicable codes and ordinances. All work must be done by a qualified electrician.**

MB500 Schematic

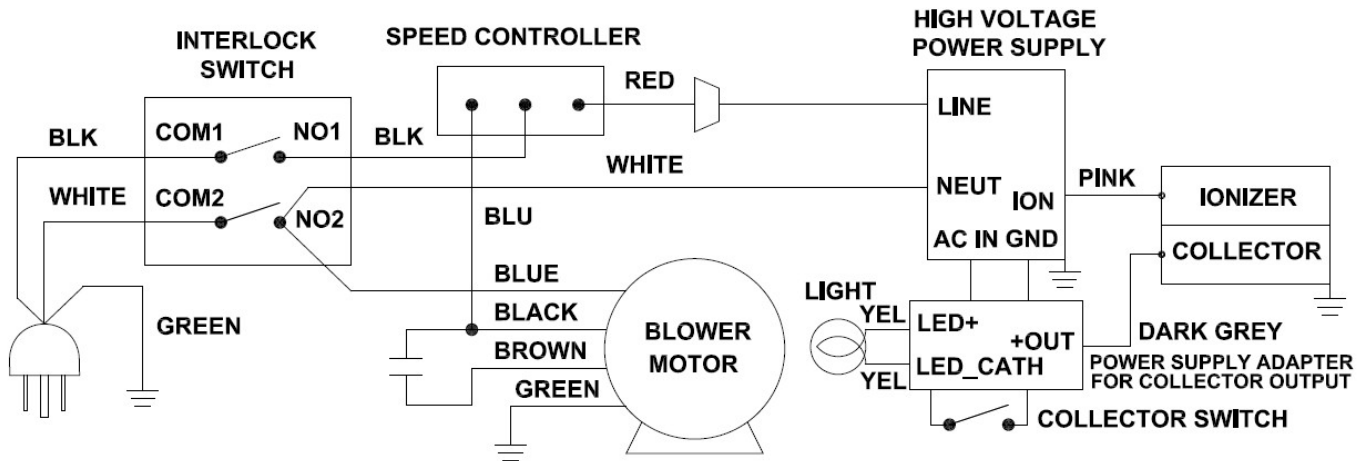

MB850C Schematic

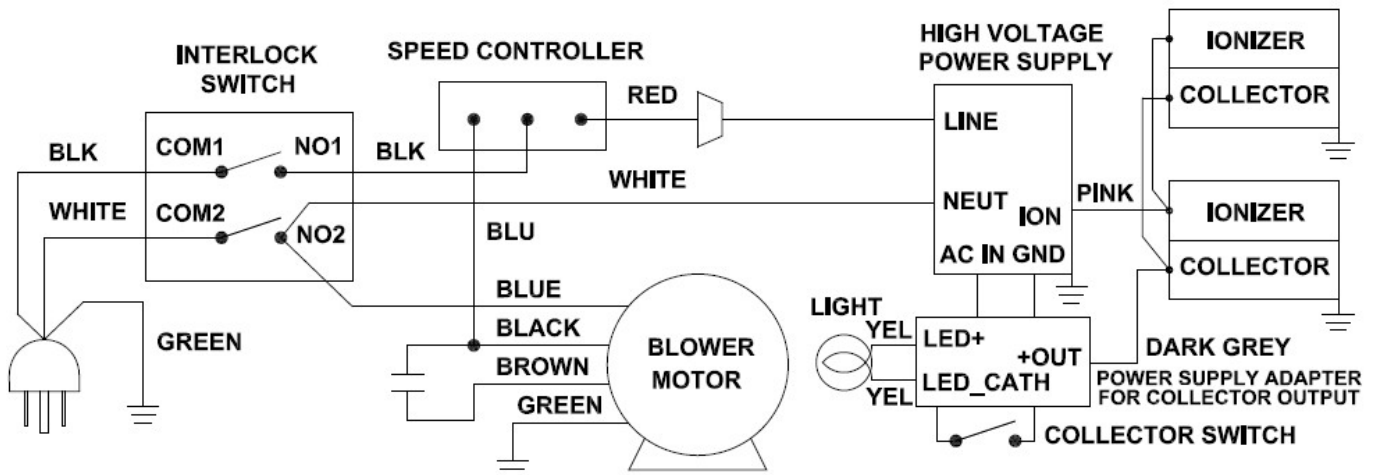

Air Quality Engineering Inc., has a policy of continuing product improvement and reserves the right to make changes in design and specification without notice.



7140 Northland Drive North, Minneapolis, MN 55428, USA
 PHONE: 763-531-9823 • TOLL FREE: 1-800-328-0787
 EMAIL: info@air-quality-eng.com • www.air-quality-eng.com

MB850 Schematic

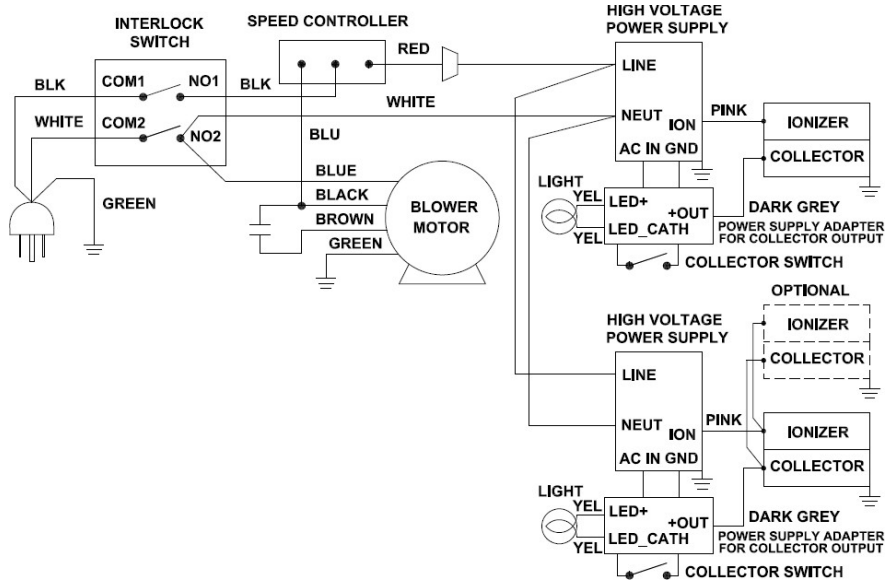

MB2000 Schematic

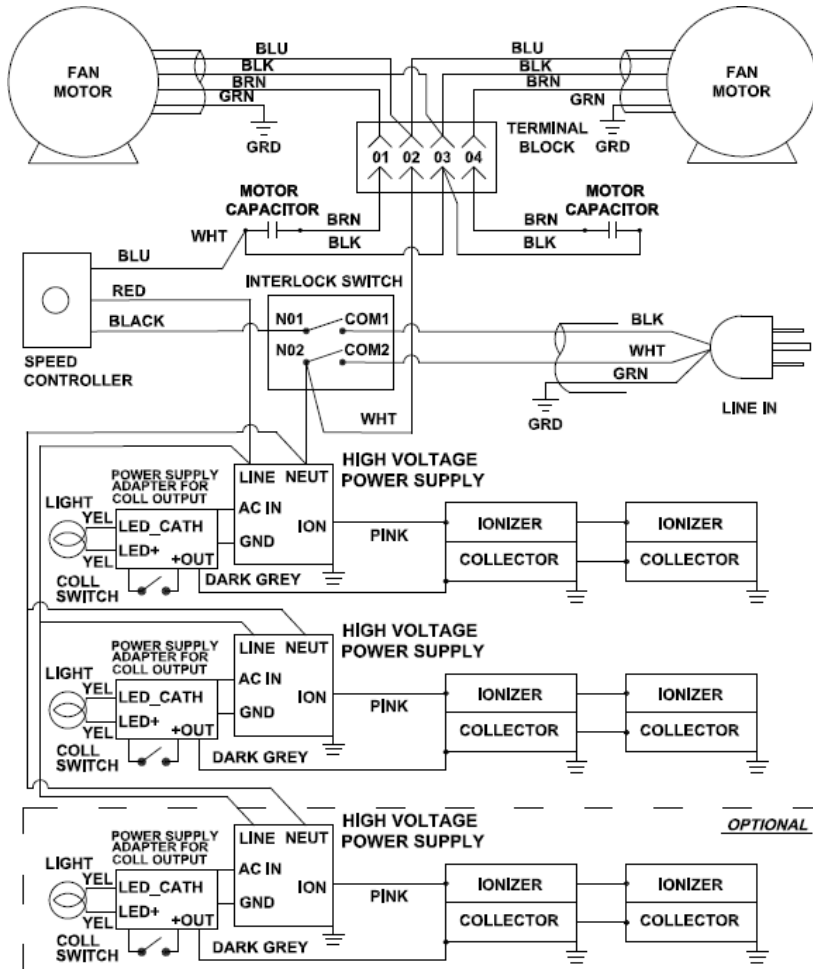

Air Quality Engineering Inc., has a policy of continuing product improvement and reserves the right to make changes in design and specification without notice.



7140 Northland Drive North, Minneapolis, MN 55428, USA
 PHONE: 763-531-9823 • TOLL FREE: 1-800-328-0787
 EMAIL: info@air-quality-eng.com • www.air-quality-eng.com

Start Up

1. Start up the MistBuster by rotating the control knob clockwise. **Set the airflow at the minimum airflow setting that will maintain the proper negative pressure. In most cases, the three o'clock setting on the speed controller will provide enough airflow to maintain negative pressure.** This will reduce noise and maintenance, and will increase efficiency.
2. The performance indicator light should be on when the blower is running.
3. Push the test button to momentarily short out the collector on the electronic cells. Arcing indicates that the cells are energized properly.
4. The coolant selector switch on the front of the MistBuster is used to compensate for nuisance arcing that occurs with some water soluble or synthetics. Switch to oil mode run the highest voltage, if nuisance arcing occurs, switch the toggle switch water mode.

Routine Maintenance

⚠ CAUTION

1. **Be extremely careful when working with the electronic cell. The edges of the collector plates and the ionizing wires on the cell may be sharp.**
2. **When cleaning the cell, be sure to wear appropriate protective gear, especially goggles and gloves. Skin contact with alkaline detergent solution should be avoided. See warning label on the detergent.**
3. **The electronic cell must be handled with care to avoid damage.**

The direct mount MistBuster captures mist droplets from machine tools using either petroleum or synthetic machining fluids. The collected fluids drain directly back into the machine tool through the inlet opening. This draining process actually helps to keep the impingers and electronic cell clean.

The mist impingers and electronic cell will need to be cleaned periodically. The exact maintenance interval is determined by each specific application. Water soluble and synthetic machining fluids will require more frequent cleaning than will petroleum machining fluids. During the first few months of operation, inspect the impingers and electronic cell. When you have an excessive buildup on the

mist impingers and electronic cell, they will need to be cleaned.

Parts Washer Method

The mist impingers and electronic cell can be cleaned with a parts washer. Make sure that the cleaning fluid used is aluminum safe and the maximum pressure does not exceed 60 psi [414kPa].

Manual Cleaning the Mist Impingers

Soak impingers in a solution of hot water and alkaline detergent for 10-15 minutes. Thoroughly rinse with hot water to remove any residual detergent.

Manual Cleaning the Electronic Cell

1. Fill the wash tub with cell cleaning detergent and hot water per the detergent manufacturer's instructions.
2. Immerse the cell in cleaner solution for five minutes.
3. Thoroughly rinse the cell with very hot water. Make certain no residue remains on the cell.
4. Inspect the collector plates for cleanliness. Repeat wash procedure, if necessary. Check for broken wires and bent collector plates. The cell can be installed back into the MistBuster. The indicator light may remain off for the normal two hour drying time.

NOTE: If water-soluble machining fluids are used, it would be best to coat the cell with AQE Cell Coat after washing the cell. See the Parts List section for the part numbers for the detergent and cell coat.

Air Quality Engineering Inc., has a policy of continuing product improvement and reserves the right to make changes in design and specification without notice.



**AIR QUALITY
ENGINEERING**

7140 Northland Drive North, Minneapolis, MN 55428, USA

PHONE: 763-531-9823 • TOLL FREE: 1-800-328-0787

EMAIL: info@air-quality-eng.com • www.air-quality-eng.com

NOTICE

1. Handle the HEPA filter carefully to avoid damage to the filter media.
2. The HEPA filter weighs 25 lbs for MB500 and MB850; 40 lbs for MB2000 clean and adds an additional 12" [305mm] to the height of the MistBuster.

1. Install the two anchor brackets to the center of both sides of the MistBuster cabinet. Remove the two bolts/washers (on each side of the MistBuster) and position the anchor bracket and bolt into place using the same bolts/washers.
2. Center the HEPA filter on top of the MistBuster exhaust grille with gasket side down. **NOTE: Airflow arrow points up towards ceiling.**

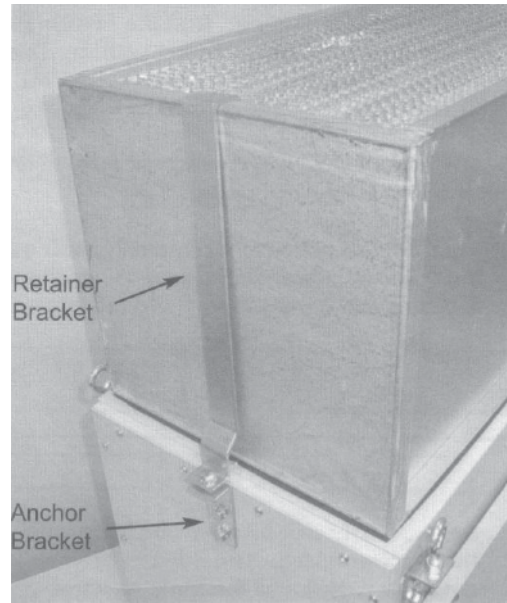
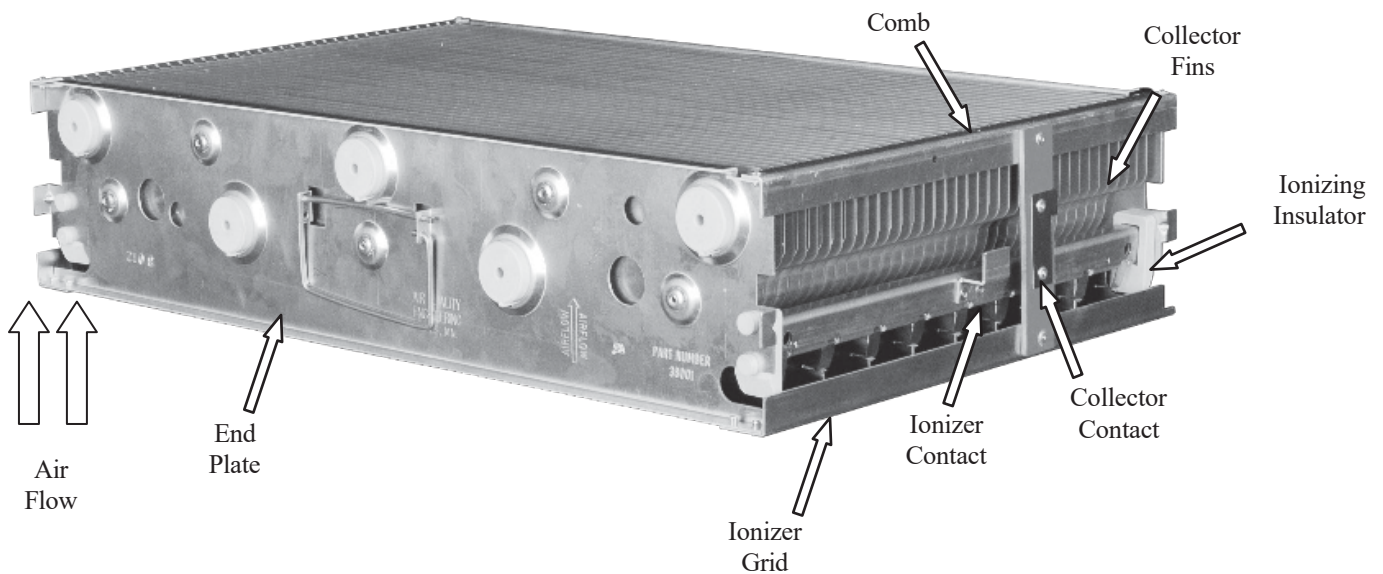

FIGURE 9

Install the HEPA retainer brackets by hooking one end to the filter frame and bolting the other end to the anchor bracket.

Cell Parts

Figure 10



Air Quality Engineering Inc., has a policy of continuing product improvement and reserves the right to make changes in design and specification without notice.

NOTE: The blower and motor in the MistBuster are integrated. The unit will not function unless the door interlock switch is depressed (i.e. the filter access door is closed.)

INDICATOR LIGHT IS ON AND MOTOR DOES NOT RUN

1. Inspect the motor by checking to see if the motor spins freely by hand. If the motor does not spin freely by hand check for obstructions or replace motor as necessary.
2. If the motor spins freely by hand try spinning the motor clockwise or counterclockwise then with the motor spinning turn the unit on. If the motor runs and the fan speed can be adjusted by the speed controller replace the motor capacitor.
3. Try bypassing the speed controller by hooking the supply voltage going into the speed controller directly to the wire that goes from the speed controller to the motor (see schematic). If the motor works with the speed controller bypassed replace the speed controller.

⚠ CAUTION

Make sure the power is off to the unit before attempting to bypass the speed controller.

INDICATOR LIGHT IS OFF AND MOTOR RUNS

1. Remove all electronic cells, close the access door and turn the unit back on. If the indicator light remains out and the motor continues to run, replace the high voltage power supply.
2. If indicator light comes back on when the electronic cells are removed, there is a short circuit in at least one of the electronic cells. Wash and inspect the cell. For instructions on how to wash the cell see the routine maintenance section of the owner's manual.

Inspect the cell for the following:

- Damaged or bent collector plates
- Damaged or bent ionizer grid fins
- Broken ionizing wires
- Dirt accumulation on the insulators
- Dirt accumulation on the collector plates
- Damaged or corroded electrical contacts
- Small metal shavings from machining
- Deformation of the cell
- The collector plates are properly seated into the slots of the comb on the cell
- Excessive corrosion on the cell

An ohmmeter may be used to check resistance between the outside frame of the cell and both the ionizer and collector contacts. In each case, the resistance should be infinite (open circuit). Anything that is bridging the gap or shrinks the gap between the energized collector plates or the energized ionizing wires can cause the indicator light to extinguish or constantly blink due to the electricity shorting out to ground. Occasional snapping or the occasional light blinking is normal.

Air Quality Engineering Inc., has a policy of continuing product improvement and reserves the right to make changes in design and specification without notice.



**AIR QUALITY
ENGINEERING**

7140 Northland Drive North, Minneapolis, MN 55428, USA

PHONE: 763-531-9823 • TOLL FREE: 1-800-328-0787

EMAIL: info@air-quality-eng.com • www.air-quality-eng.com

INDICATOR LIGHT IS CONSTANTLY BLINKING AND THE MOTOR RUNS

1. If coolant selector switch is in oil mode, move coolant selector switch to the water-based mode.
2. If indicator light flashes in both the water-based mode and the oil mode, remove all electronic collector cells, close the door and energize the unit again.
3. If indicator light continues to flash even without the electronic cell(s) installed, clean or replace the contact boards mounted in the cabinet. Note – clean the red, phenolic material of the board, not the electrical contacts themselves.
4. If the indicator light blinks in either the water soluble or oil mode, and stops blinking when the electronic cells are removed, there is a problem with at least one of the electronic collector cells. Wash and inspect the cell. For instructions on how to wash the cell see the routine maintenance section of the owner's manual.

Inspect the cell for the following:

- Damaged or bent collector plates
- Damaged or bent ionizer grid fins
- Broken ionizing wires
- Dirt accumulation on the insulators
- Dirt accumulation on the collector plates
- Damaged or corroded electrical contacts
- Small metal shavings from machining
- Deformation of the cell
- The collector plates are properly seated into the slots of the comb on the cell
- Excessive corrosion on the cell

INDICATOR LIGHT IS OFF AND MOTOR DOES NOT RUN

1. Make sure the unit is getting power and is getting the correct voltage.
2. Check to make sure the interlock switch is working properly. Make sure there is voltage passing through the interlock switch when the button for the interlock switch is depressed. With the power disconnected to the unit an ohm meter can be used to check if the interlock switch has continuity when the switch is depressed. The interlock switch has two sets of contacts that are individually switched and will not have continuity between the two separated contacts. If there is no continuity replace interlock switch as needed.
3. With the unit on, check to see if the power supply and motor are getting voltage. If the interlock is functioning properly and there is no power reading to the power supply or motor, check wiring and replace the speed controller as needed.

Air Quality Engineering Inc., has a policy of continuing product improvement and reserves the right to make changes in design and specification without notice.



**AIR QUALITY
ENGINEERING**

7140 Northland Drive North, Minneapolis, MN 55428, USA
PHONE: 763-531-9823 • TOLL FREE: 1-800-328-0787
EMAIL: info@air-quality-eng.com • www.air-quality-eng.com

INDICATOR LIGHT IS ON AND MOTOR DOES NOT CHANGE SPEED

1. Adjust the speed controller fine adjustment. To get to the fine adjustment on the speed controller pull the knob off the speed controller and slide the silver plate behind the speed controller knob up (there is no fasteners holding the speed controller knob or the silver plate on). There is a small hole next to the main adjustment for the speed controller that you can insert a small screwdriver to adjust.
2. If adjusting the fine adjustment does not change the fan speed replace the speed controller.

INDICATOR LIGHT IS ON, MOTOR RUNS, AND MIST / SMOKE IS COMING OUT THE EXHAUST

1. Try reducing the speed of the motor to increase the amount of time the electrostatic cells have to collect the mist / smoke.
3. If the application that the unit was installed in has changed (i.e. higher coolant pressure, shorter cycle times, machine has changed, etc.) the unit might not be able to handle the increased load.

INDICATOR LIGHT IS ON, MOTOR RUNS, AND MIST / SMOKE IS NOT BEING EVACUATED / CAPTURED

1. Make sure there are no obstructions in the ducting or the unit.
2. Make sure there is proper airflow. If the unit is installed too close to openings on the machine cavity the unit will pull in fresh air from the opening and not move / draw into the unit from where the mist / smoke is being generated.
3. If long lengths of ducting / tubing are used the airflow can be drastically reduced. The same issue can result when using ducting / tubing that has a very small diameter.

For additional assistance with troubleshooting or to order replacement parts, please contact your local sales office or call **1-800-328-0787** for the manufacturer.

Air Quality Engineering Inc., has a policy of continuing product improvement and reserves the right to make changes in design and specification without notice.



**AIR QUALITY
ENGINEERING**

7140 Northland Drive North, Minneapolis, MN 55428, USA
PHONE: 763-531-9823 • TOLL FREE: 1-800-328-0787
EMAIL: info@air-quality-eng.com • www.air-quality-eng.com

LIMITED THREE-YEAR WARRANTY

Air Quality Engineering, Inc., (AQE) warrants the MistBuster® Air Cleaner to be free from defects in workmanship or materials, under normal use and service, for a period of three (3) years from date of purchase by the consumer. If, at any time during the warranty period, the product is defective or malfunctions, AQE shall repair or replace it (at AQE's option) within a reasonable period of time.

If the product is defective:

- (i) return the unit or defective component, with a bill of sale or other dated proof of purchase, to the retailer from which you purchased it, or
- (ii) package the unit or component, along with proof of purchase (including date purchased) and a short description of the malfunction, and mail or ship, postage or freight prepaid, to the following address:

**AIR QUALITY ENGINEERING, INC.
Warranty/Return Goods Department
7140 Northland Drive North
Minneapolis, Minnesota 55428 USA**

The repaired or replaced part or unit will be shipped by AQE to the purchaser, freight collect, with the purchaser to be responsible for all freight charges. The warranty on any repaired or replacement part shall be for a duration of time no longer than the remaining or unexpired term of the original warranty. This warranty does not cover any labor or other service charges incurred by the purchaser.

This warranty shall not apply if it is shown by AQE that the defect or malfunction was caused by damage, which occurred while the product was in the possession of the consumer.

AQE's sole responsibility shall be to repair or replace the product within the terms stated above. AQE SHALL NOT BE LIABLE FOR ANY CONSEQUENTIAL DAMAGES RESULTING FROM ANY BREACH OF WARRANTY, EXPRESS OR IMPLIED, APPLICABLE TO THIS PRODUCT. Some states do not allow the exclusion or limitation of consequential damages, so this limitation may not apply to you.

THIS WARRANTY IS IN LIEU OF ALL OTHER WARRANTIES, EXPRESS OR IMPLIED, AND THE WARRANTIES OF MERCHANTABILITY AND FITNESS FOR A PARTICULAR PURPOSE ARE HEREBY EXCLUDED BEYOND THE THREE-YEAR DURATION OF THIS WARRANTY. Some states do not allow limitations on how long an implied warranty lasts, so the above limitation may not apply to you.

This warranty gives you specific legal rights and you may also have other rights that vary from state to state.

AIR QUALITY ENGINEERING, INC.
7140 NORTHLAND DRIVE NORTH
MINNEAPOLIS, MN 55428

TELEPHONE: (763) 531-9823
TOLL FREE: 800-328-0787
FAX: (763) 531-9900

MANUFACTURER & WORLDWIDE DISTRIBUTOR OF SMOKEMASTER® AIR CLEANING SYSTEMS
WEBSITE: <http://www.air-quality-eng.com/> E-MAIL: info@air-quality-eng.com

Made in the USA

PN: OM-0003 Rev. B

Air Quality Engineering Inc., has a policy of continuing product improvement and reserves the right to make changes in design and specification without notice.



7140 Northland Drive North, Minneapolis, MN 55428, USA
PHONE: 763-531-9823 • TOLL FREE: 1-800-328-0787
EMAIL: info@air-quality-eng.com • www.air-quality-eng.com